

- NOTES:**
1. BASEPLATE MINIMUM LENGTH S = .50.
  2. OVERALL MINIMUM LENGTH L = S + T MIN.
  3. STUD SUPPLIED WITH ELECTRICAL GROUNDING SCREW INSTALLED IN BASEPLATE. THREADED STUD SHALL BE INSTALLED BY CUSTOMER (SEE PAGE 3).

**BASEPLATE MATERIAL AND FINISH DATA**

CODE	MATERIAL	SPEC.	PASSIVATE
CR	304 CRES	AMS 5513, 5639, OR 5647	AMS 2700
CRM	316 CRES	AMS 5507, 5524, 5648, 5649, 5653, OR 5907	AMS 2700

**THREADED STUD MATERIAL DATA**

CODE	MATERIAL	PASSIVATE
CR	18-8 CRES	AMS 2700
CRM	316 CRES	AMS 2700

**COARSE THREAD DIMENSION DATA**

CODE	THREAD SIZE	D DIA	T MIN
324	.1900-24 UNC-3A	.500	.250
420	.2500-20 UNC-3A	.500	.312
518	.3125-18 UNC-3A	.625	.375
616	.3750-16 UNC-3A	.750	.437
813	.5000-13 UNC-3A	1.000	.562

**FINE THREAD DIMENSION DATA**

CODE	THREAD SIZE	D DIA	T MIN
3	.1900-32 UNF-3A	.500	.250
4	.2500-28 UNF-3A	.500	.312
5	.3125-24 UNF-3A	.625	.375
6	.3750-24 UNF-3A	.750	.437
8	.5000-20 UNF-3A	1.000	.562

**ELECTRICAL GROUNDING SCREW**

MATERIAL	PASSIVATE
18-8 CRES	AMS 2700

**OPTIONAL BASEPLATE PRIMER**

CODE	MATERIAL SPEC.
-	NONE
P	MIL-PRF-85582

**EXAMPLE PART NUMBER**

CB9784 CRM 420 CRM 10 P 20 F T

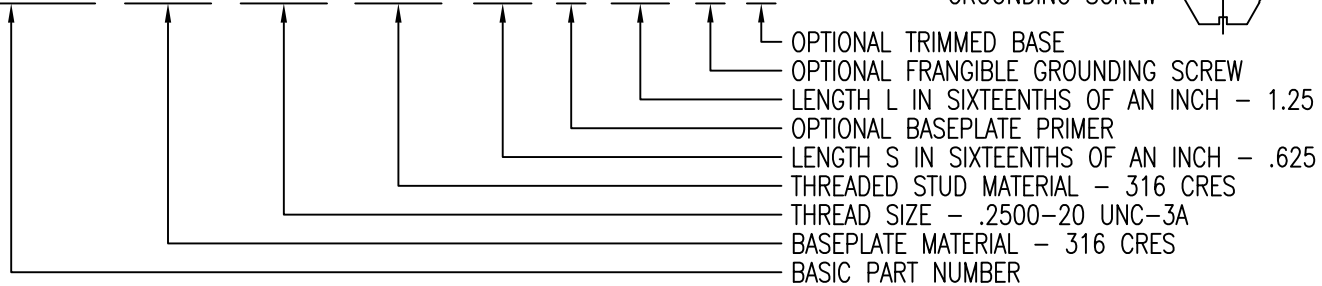

SCALE 2X  
OPTIONAL FRANGIBLE  
GROUNDING SCREW

UNLESS OTHERWISE SPECIFIED, ALL DIMENSIONS ARE IN INCHES AND TOLERANCES ARE AS SHOWN BELOW. DIMENSIONAL TOLERANCES AND SYMBOLS PER ANSI Y14.5M-1982.

PROPRIETARY PARTS SHOWN IN THIS DRAWING ARE THE SUBJECT OF ISSUED UNITED STATES AND FOREIGN PATENTS AND PATENTS PENDING. UNAUTHORIZED REPRODUCTION AND/OR DISTRIBUTION OF THIS DRAWING IS SPECIFICALLY PROHIBITED.



CARSON CITY  
NEVADA 89706

CAD CB9784-1		APPROVALS	DATE	TITLE			
ANGLES	±1°	DRAWN	8NOV12	STUD, ELECTRICAL GROUNDING SPACER, LARGE BASE			
.XX	±.03	CHECKED	28NOV17	SIZE	CAGE CODE	DWG. NO.	REV.
.XXX	±.010	RELEASED	29NOV17	A	66530	CB9784	3
.XXXX	±.001	REVISED	27NOV17	SCALE	1/1	27NOV17	SHEET 1 OF 3

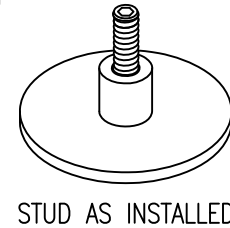
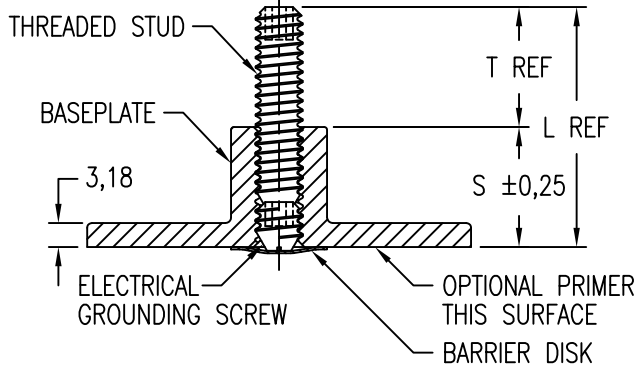
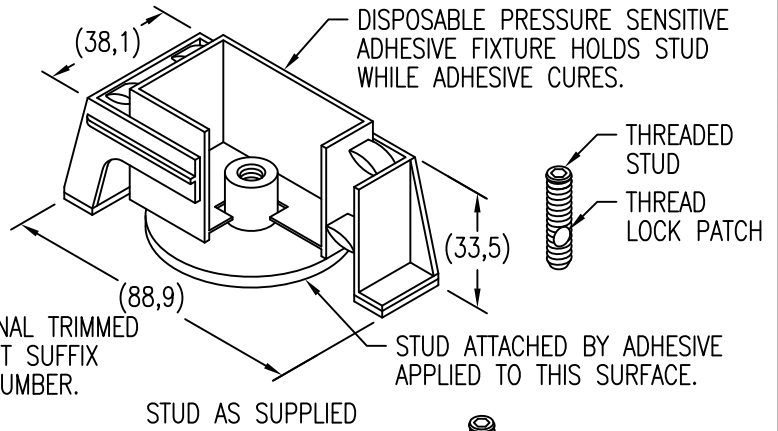
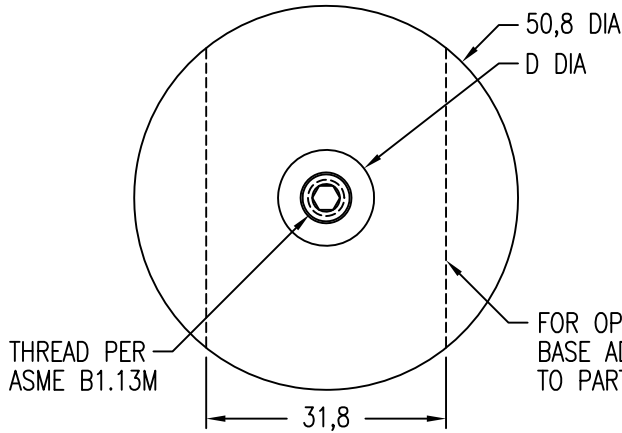

**NOTES:**

1. BASEPLATE MINIMUM LENGTH S = 12,7.
2. OVERALL MINIMUM LENGTH L = S + T MIN.
3. STUD SUPPLIED WITH ELECTRICAL GROUNDING SCREW INSTALLED IN BASEPLATE. THREADED STUD SHALL BE INSTALLED BY CUSTOMER (SEE PAGE 3).

**BASEPLATE MATERIAL AND FINISH DATA**

CODE	MATERIAL	SPEC.	PASSIVATE
CR	304 CRES	AMS 5513, 5639, OR 5647	AMS 2700
CRM	316 CRES	AMS 5507, 5524, 5648, 5649, 5653, OR 5907	AMS 2700

**THREADED STUD MATERIAL DATA**

CODE	MATERIAL	PASSIVATE
CR	18-8 CRES	AMS 2700
CRM	316 CRES	AMS 2700

**THREAD AND DIMENSION DATA**

CODE	THREAD SIZE	D DIA	T MIN
5M	M5 X 0,8 6g	12,7	6,3
6M	M6 X 1,0 6g	12,7	7,9
8M	M8 X 1,25 6g	15,9	9,5
10M	M10 X 1,50 6g	19,1	11,1
12M	M12 X 1,75 6g	25,4	14,2

**OPTIONAL BASEPLATE PRIMER**

CODE	MATERIAL SPEC.
NONE	NONE
P	MIL-PRF-85582

**ELECTRICAL GROUNDING SCREW**

MATERIAL	PASSIVATE
18-8 CRES	AMS 2700

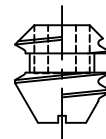

SCALE 2X  
OPTIONAL FRANGIBLE  
GROUNDING SCREW

**EXAMPLE PART NUMBER**

CB9784 CRM 6M CRM 15M P 32M F T

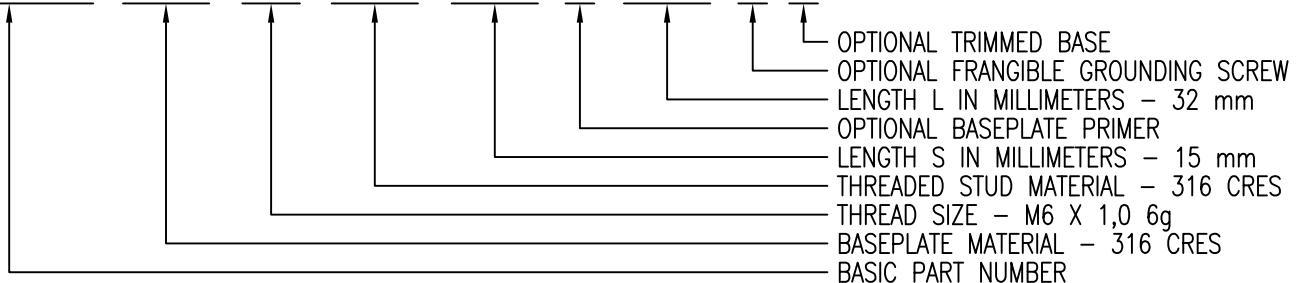

UNLESS OTHERWISE SPECIFIED, ALL DIMENSIONS ARE IN MILLIMETERS AND TOLERANCES ARE AS SHOWN BELOW. DIMENSIONAL TOLERANCES AND SYMBOLS PER ANSI Y14.5M-1982.

PROPRIETARY PARTS SHOWN IN THIS DRAWING ARE THE SUBJECT OF ISSUED UNITED STATES AND FOREIGN PATENTS AND PATENTS PENDING. UNAUTHORIZED REPRODUCTION AND/OR DISTRIBUTION OF THIS DRAWING IS SPECIFICALLY PROHIBITED.

**CLICK BOND**

CARSON CITY  
NEVADA 89706

CAD CB9784-2 METRIC DIMENSIONS	
ANGLES	±1°
.X	±0,8
.XX	±0,25

APPROVALS	DATE
DRAWN <i>DAC</i>	8NOV12
CHECKED <i>DAC/mtm</i>	28NOV17
RELEASED <i>ADAL</i>	29NOV17
REVISED <i>BPEREZ</i>	27NOV17

TITLE STUD, ELECTRICAL GROUNDING SPACER, LARGE BASE			
SIZE	CAGE CODE	DWG. NO.	REV.
A	66530	CB9784 (METRIC)	3
SCALE	1/1		27NOV17
SHEET 2 OF 3			

1. BOND BASEPLATE TO THE METALLIC BULKHEAD. AFTER ADHESIVE CURES, REMOVE THE DISPOSABLE FIXTURE.

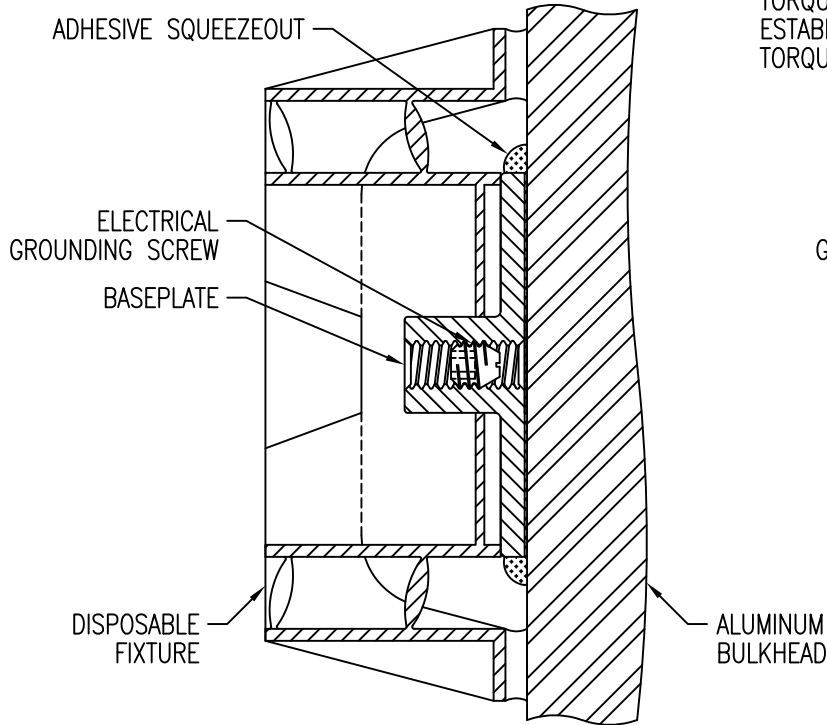

2. SEAT THE ELECTRICAL GROUNDING SCREW USING A HEX WRENCH. THE FRANGIBLE GROUNDING SCREW OPTION (F) PREVENTS OVER TORQUEING. APPLY 40-60 IN-LBS OF TORQUE TO PARTS WITHOUT THE FRANGIBLE OPTION, ESTABLISHING THE ELECTRICAL CONNECTION. EXCESSIVE TORQUE MAY CAUSE PART OR ADHESIVE FAILURE.

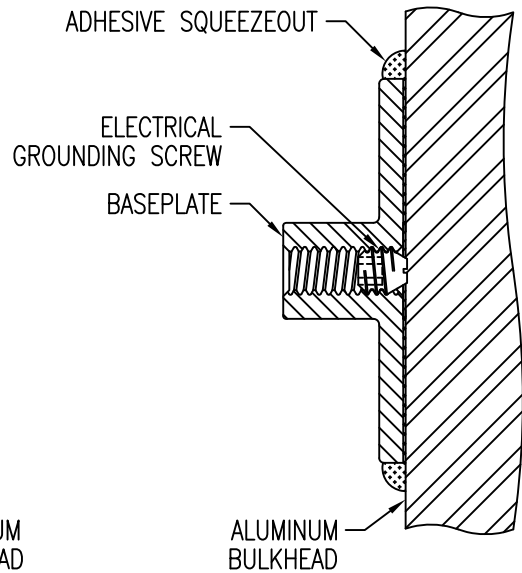

3. INSTALL THE THREADED STUD INTO THE BASEPLATE. SEAT THE STUD USING A HEX WRENCH ONTO ELECTRICAL GROUNDING SCREW. TIGHTEN TO APPLY 140 TO 150 IN-LBS OF TORQUE.

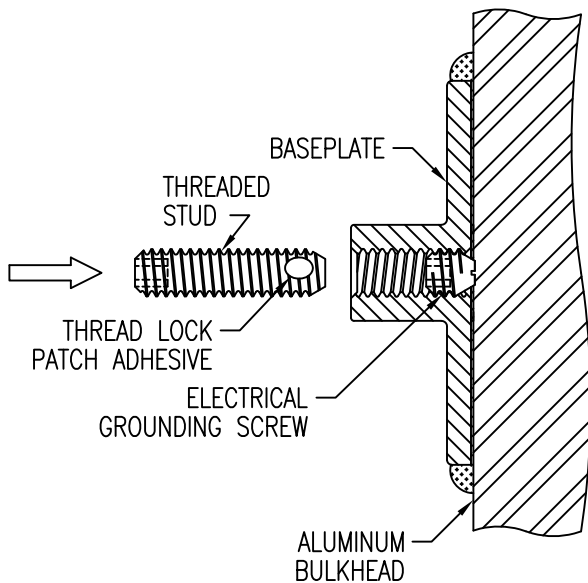

4. CHECK FOR ELECTRICAL CONTINUITY WITH OHMMETER. INSTALLATION IS COMPLETE.

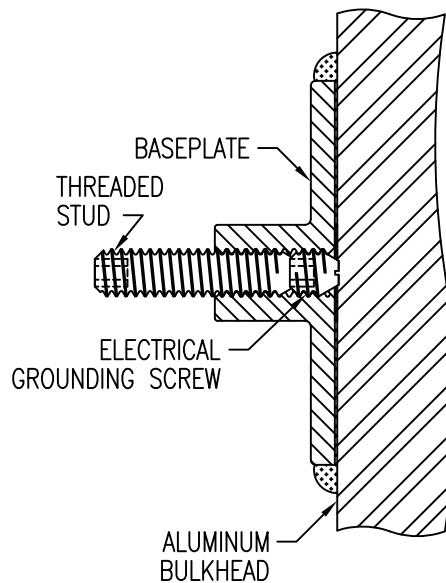

UNLESS OTHERWISE SPECIFIED, ALL DIMENSIONS ARE IN INCHES AND TOLERANCES ARE AS SHOWN BELOW. DIMENSIONAL TOLERANCES AND SYMBOLS PER ANSI Y14.5M-1982.

PROPRIETARY PARTS SHOWN IN THIS DRAWING ARE THE SUBJECT OF ISSUED UNITED STATES AND FOREIGN PATENTS AND PATENTS PENDING. UNAUTHORIZED REPRODUCTION AND/OR DISTRIBUTION OF THIS DRAWING IS SPECIFICALLY PROHIBITED.

**CLICK BOND**

CARSON CITY  
NEVADA 89706

CAD CB9784-3

APPROVALS

DATE

TITLE

ANGLES ±1°

DRAWN *DAC*

8NOV12

STUD, ELECTRICAL GROUNDING SPACER, LARGE BASE

.XX ±.03

CHECKED *DAC/mtm*

28NOV17

SIZE

CAGE CODE

DWG. NO.

REV.

.XXX ±.010

RELEASED *ADAL*

29NOV17

A

66530

CB9784

3

.XXXX ±.001

REVISED *BPEREZ*

27NOV17

SCALE

1/1

27NOV17

SHEET 3 OF 3