

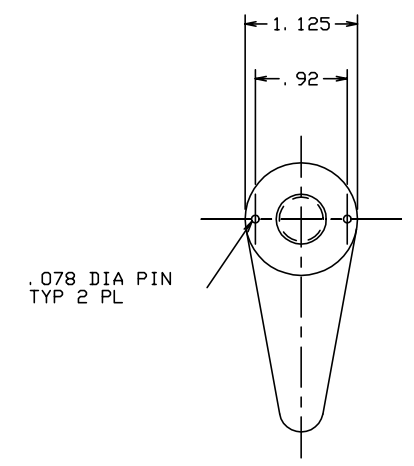

THE INFORMATION AND DESIGN HEREIN WAS ORIGINATED BY AND IS THE PROPERTY OF SKYLOCK INDUSTRIES INCORPORATED. SKYLOCK INDUSTRIES INCORPORATED RESERVES ALL PATENT, PROPRIETARY, DESIGN MANUFACTURING, REPRODUCTION, USE AND SALES RIGHTS THERE TO, AND TO ANY ARTICLE DISCLOSED THEREIN EXCEPT TO THE EXTENT RIGHTS ARE EXPRESSLY GRANTED TO OTHERS. THE FOREGOING DOES NOT APPLY TO VENDOR PROPRIETARY PARTS.

REVISIONS				
ZONE	LTR	DESCRIPTION	DATE	APPROVED
	NC	PRODUCTION RELEASE	11-11-88	T. S.
	A	REDRAWN, ADDED -403/-404	4-4-95	T. CSIK

- NOTES: UNLESS OTHERWISE SPECIFIED.
- REMOVE ALL BURRS AND BREAK SHARP EDGES.
 - MAT'L: RETAINER; ALUM. ALLOY, ALL OTHER PARTS; 300 SERIES CRES.
 - FINISH: ALUM.; ANODIZE, CRES PARTS; PASSIVATE.
 - DECORATIVE FINISH: RETAINER; BRIGHT BUFF AND CANDY APPLE RED ANODIZE.
 - SHAFT NEEDS NO TORQUE ADJUSTMENT. TIGHTEN SHAFT AS MUCH AS POSSIBLE WHEN INSTALLING RETAINER.

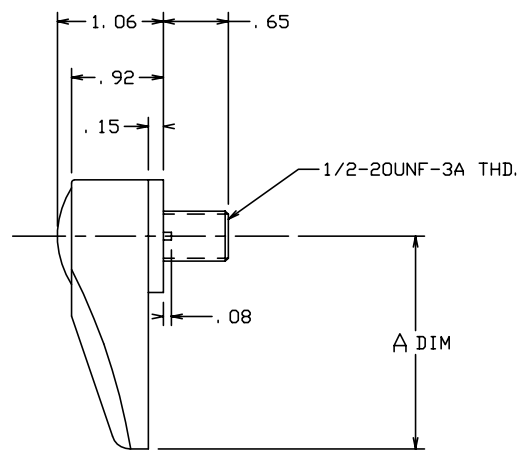
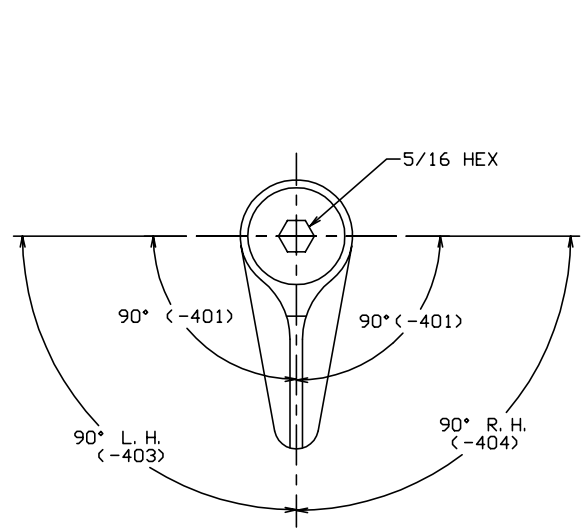

2. 13	-404	RETAINER ASSY	<90° RIGHT HAND
2. 13	-403	RETAINER ASSY	<90° LEFT HAND
2. 13	-401	RETAINER ASSY	<180°, DETENTED AT 90°

A DIM	PART NO.	DESCRIPTION	MATERIAL	SIZE	SPECIFICATION
PARTS LIST					
UNLESS OTHERWISE SPECIFIED		DRAWN BY T. CSIK	4-4-95	 SKYLOCK INDUSTRIES INCORPORATED MONROVIA CALIFORNIA U. S. A.	
DIMENSIONS ARE IN INCHES		CHECKED			
TOLERANCES ON		ENGINEER			
DECIMALS ANGLES DRILLED HOLES		PROJECT			
.X ± .1 ± 0° 30' AND 10387		APPROVAL		1/4 TURN RETAINER	
.XX ± .03		APPROVAL			
.XXX ± .010		APPROVAL			
DO NOT SCALE THIS DRAWING					
MATERIAL - FINISH		USED ON	SIZE	CODE IDENT. NO.	DRAWING NO.
NEXT ASSY			C	51941	20629
FINAL ASSY			SCALE	1: 1	VT.
			SHEET 1 OF 1		REV. A