

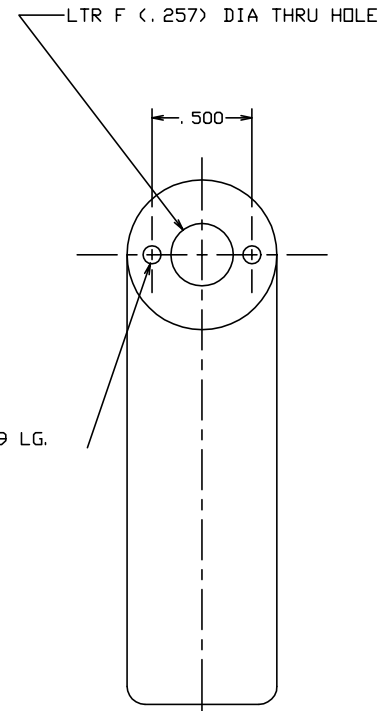

THE INFORMATION AND DESIGN HEREIN WAS ORIGINATED BY AND IS THE PROPERTY OF SKYLOCK INDUSTRIES INCORPORATED. SKYLOCK INDUSTRIES INCORPORATED RESERVES ALL PATENT, PROPRIETARY, DESIGN MANUFACTURING, REPRODUCTION, USE AND SALES RIGHTS THERE TO, AND TO ANY ARTICLE DISCLOSED THEREIN EXCEPT TO THE EXTENT RIGHTS ARE EXPRESSLY GRANTED TO OTHERS. THE FOREGOING DOES NOT APPLY TO VENDOR PROPRIETARY PARTS.

REVISIONS				
ZONE	LTR	DESCRIPTION	DATE	APPROVED
	NC	PRODUCTION RELEASE	2-10-93	T. CSIK

- NOTES: UNLESS OTHERWISE SPECIFIED.
1. REMOVE ALL BURRS AND BREAK SHARP EDGES.
  2. MAT'L: RETAINER; 7075-T651 ALUM. ALLOY, ALL OTHER PARTS; 300 SERIES CRES.
  3. FINISH: CRES PARTS; PASSIVATE.
  4. DECORATIVE FINISH: RETAINER; BRIGHT BUFF AND CANDY APPLE RED ANODIZE.
  5. STATIC LOAD: 1300 LBS. MAX.
  6. RETAINER IS DETENTED AT EACH 90°.

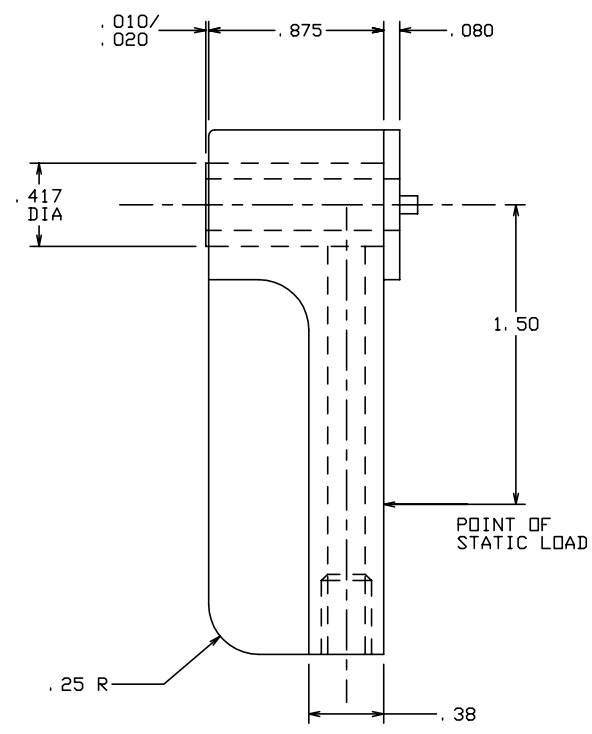
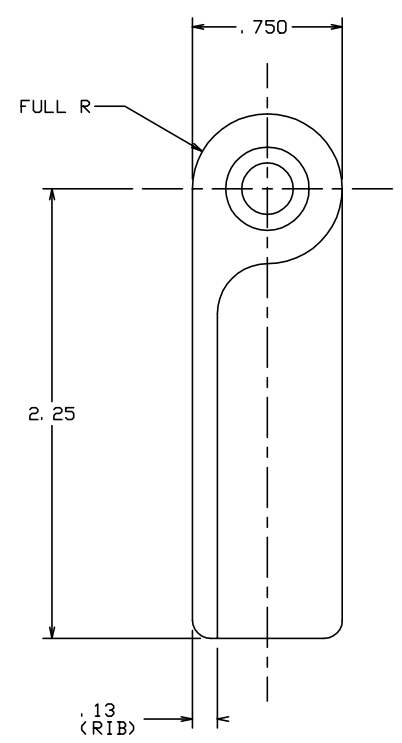

	-2	RETAINER ASSY	OPP. (RIGHT HAND WEB)	
	-1	RETAINER ASSY	SHOWN (LEFT HAND WEB)	
	PART NO.	DESCRIPTION	MATERIAL SIZE SPECIFICATION	ITEM NO.
PARTS LIST				
UNLESS OTHERWISE SPECIFIED		DRAWN BY T. CSIK	2-10-93	 SKYLOCK INDUSTRIES INCORPORATED MONROVIA CALIFORNIA U. S. A.
DIMENSIONS ARE IN INCHES		CHECKED		
TOLERANCES ON		ENGINEER		
DECIMALS ANGLES DRILLED HOLES		PROJECT		
.X ± .1 ± 0° 30' AND 10387		APPROVAL T. CSIK	2-10-93	1/4 TURN RETAINER
.XX ± .03		APPROVAL		
.XXX ± .010				
DO NOT SCALE THIS DRAWING				
MATERIAL - FINISH		USED ON	SIZE C	CODE IDENT. NO. 51941
NEXT ASSY				DRAWING NO. 20811
FINAL ASSY			SCALE 2:1	REV. NC
			WT.	SHEET 1 OF 1