

THE INFORMATION AND DESIGN HEREIN WAS ORIGINATED BY AND IS THE PROPERTY OF SKYLOCK INDUSTRIES INCORPORATED. SKYLOCK INDUSTRIES INCORPORATED RESERVES ALL PATENT, PROPRIETARY, DESIGN MANUFACTURING, REPRODUCTION, USE AND SALES RIGHTS THERE TO, AND TO ANY ARTICLE DISCLOSED THEREIN EXCEPT TO THE EXTENT RIGHTS ARE EXPRESSLY GRANTED TO OTHERS. THE FOREGOING DOES NOT APPLY TO VENDOR PROPRIETARY PARTS.

REVISIONS				
ZONE	LTR	DESCRIPTION	DATE	APPROVED
	A	REVISED / REDRAWN	8/7/78	JEE
	B	SEE CHG NOTICE 10302	9/9/78	JEE
	C	SEE CHG NOTICE 10323	4/2/79	JEE
	D	SEE CHG NOTICE 10409	7/12/79	JEE
	E	REDRAWN IN AUTOCAD	12/23/98	T. CSIK

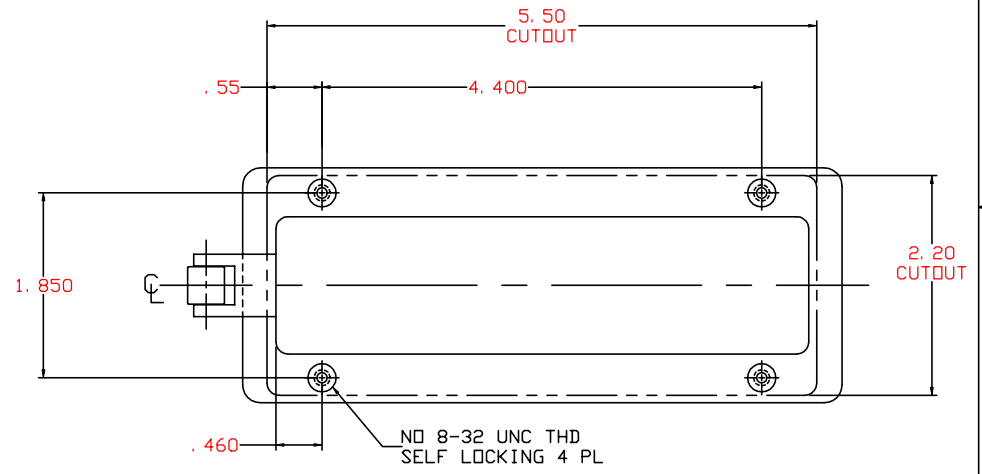

VIEW A-A

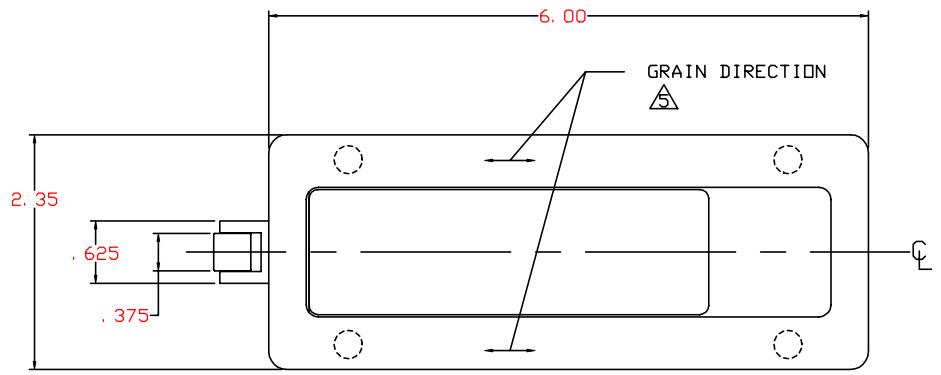
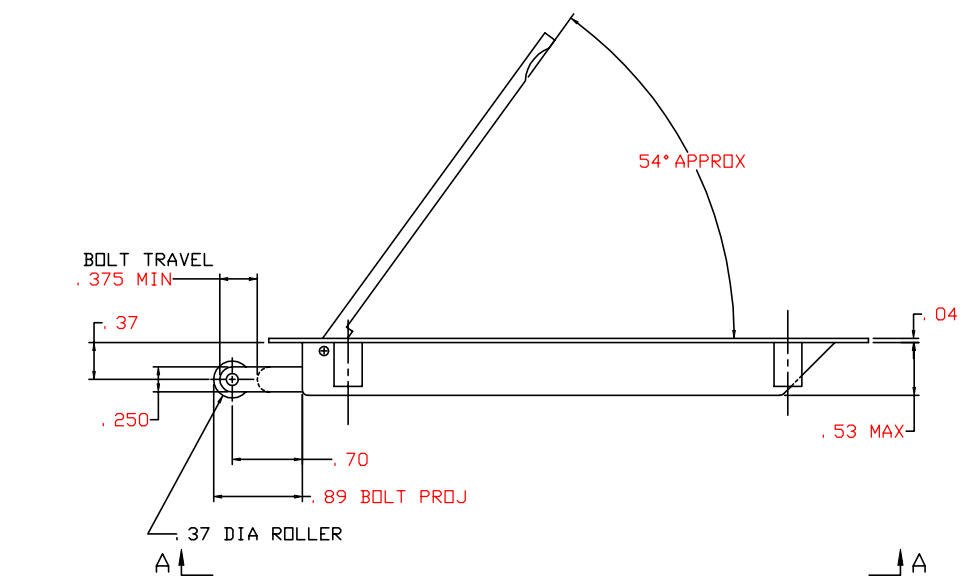

6. PER FAR 45.15. PARTS WILL IDENTIFIED WITH:
1. FAA-PMA.
 2. SKYLOCK IND. INC.
 3. PART NO.
 4. AIRCRAFT ELIGIBILITY.

- △ HANDLE WILL NOT RETURN TO CLOSED POSITION UNLESS BOLT IS FULLY ENGAGED.
- 4 DECORATIVE FINISH: SATIN BRUSH LENGTHWISE TO PART SURFACE.
 - 3 FINISH: PASSIVATE PER AMS-QQ-P-35, TYPE II, (303), TYPEVI OR VII, (304).
 - 2 MAT'L: 303/304 CRES, CONDITION A, PER ASTM-A240, OR EQUIV.

1. REMOVE ALL BURRS AND SHARP CORNERS.
 NOTES: UNLESS OTHERWISE SPECIFIED

-1 LATCH ASSY					
ADIM	PART NO.	DESCRIPTION	MATERIAL	SIZE APPLICATION	ITEM NO.
PARTS LIST					
UNLESS OTHERWISE SPECIFIED		DRAWN BY	JEE	8/7/78	SKYLOCK INDUSTRIES INCORPORATED MONROVIA CALIFORNIA U. S. A.
DIMENSIONS ARE IN INCHES		CHECKED	D. VO	12/21/98	
TOLERANCES ON		ENGINEER	T. CSIK	12/23/98	
DECIMALS ANGLES DRILLED HOLES		MFG	P. MATSUOKA	12/29/98	
.X .1		Q.C.	J. VIVIRITO	12/29/98	LATCH ASSY REFER DOOR
.XX .03		DO NOT SCALE THIS DRAWING			
.XXX .010		MATERIAL - FINISH			SIZE C CODE IDENT. NO. 51941 DRAWING NO. 20281 REV. E
MANUFACTURED IN ACCORDANCE WITH SKYLOCK IND. INC. QUALITY CONTROL MANUAL QC.001			SCALE 1:1		VT. SHEET 1 OF 1