

REVISIONS			
SYM	DESCRIPTION	E	BY
	EFFECTIVE ON	DISP	EXIST PARTS
			APPROVAL

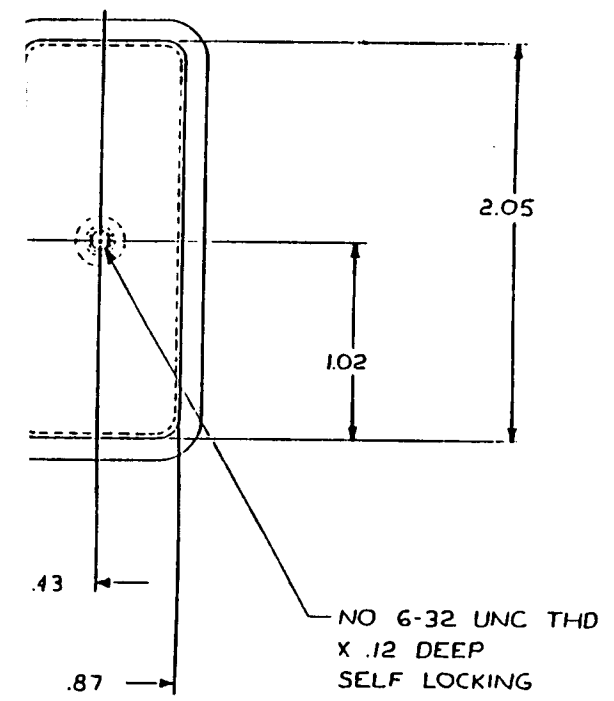
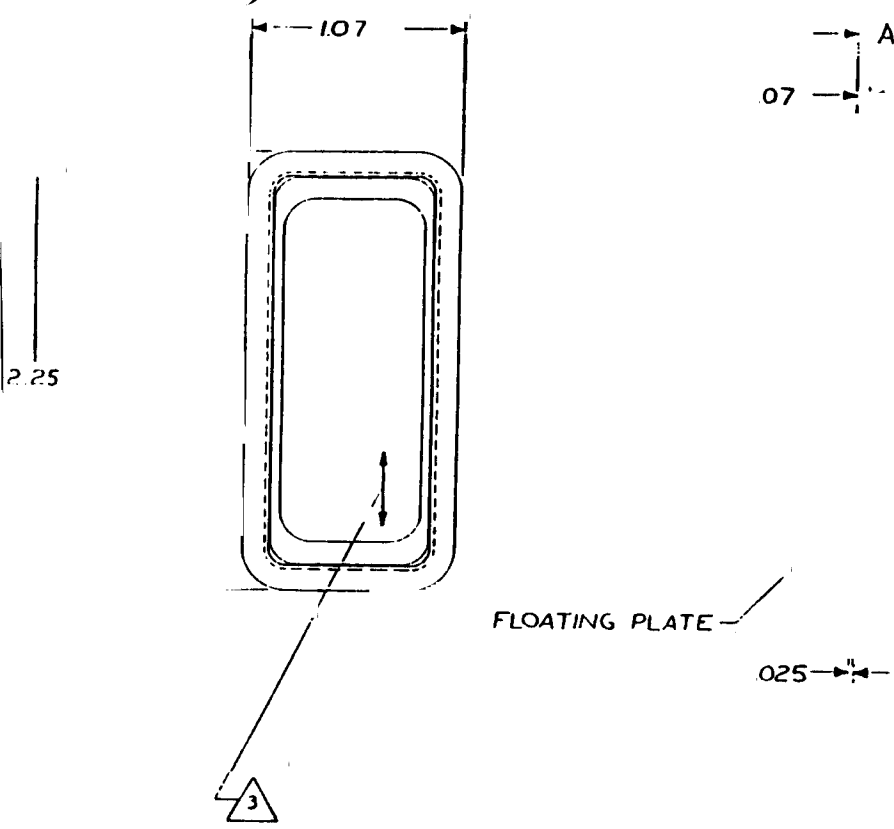

REQD	PART NUMBER	DESCRIPTION	MATERIAL OR NOTE
.47	- 3	PLATE ASSY	
.312	- 1	PLATE ASSY	

LIST OF MATERIAL

UNLESS OTHERWISE NOTED DIMENSIONS ARE IN INCHES. TOLERANCES ON DECIMALS .XX ± .03 .XXX ± .010 ANGLES ± DRILLED HOLES PER ANSI Q13.1		CONTRACT NO.		SKYLOCK INDUSTRIES, INC. 50. EL MONTE, CALIFORNIA	
SURFACE ROUGHNESS		DRAFTSMAN	JEE	PLATE ASSEMBLY MAGNETIC HANDLE HOLDER	
HEAT TREAT		CHECKER		C	
FINISH		ENGINEER	J.E.C.	CODE IDENT NO.	20293
INSPECT		PROD. APPD		SCALE	2 / 1
REF. NO.		APPROVAL	D.Y.A.	WT CALC	WT ACT
NEXT ASSY		USED ON		SHEET 1 OF 1	
APPLICATION					

PROTECTIVE FINISH : CRES - PASSIVATE ,  
STEEL - CAD PLATE  
MAT'L : CASE - CRES , PAD - FOAM RUBBER  
FLOATING PLATE - STEEL

NOTES : UNLESS OTHERWISE SPECIFIED

20293

B

A