

SYM	DESCRIPTION	DATE	BY
A	EFFECTIVE ON DISP EXIST PARTS	11-17-85	FAS
A	SEE DCN 1093L		

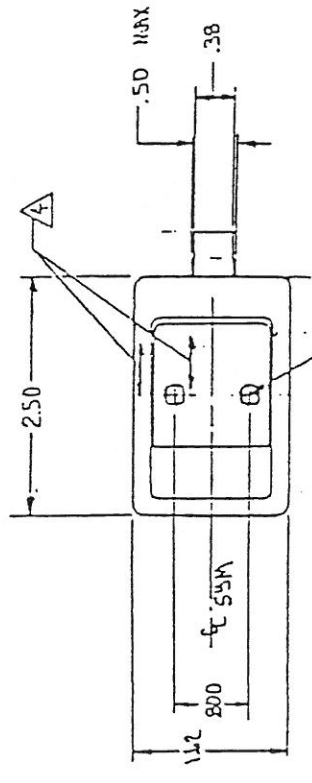

10-32 UNIF. 2.8 TYP
SELF DRILLING
TYP 2 PLACES

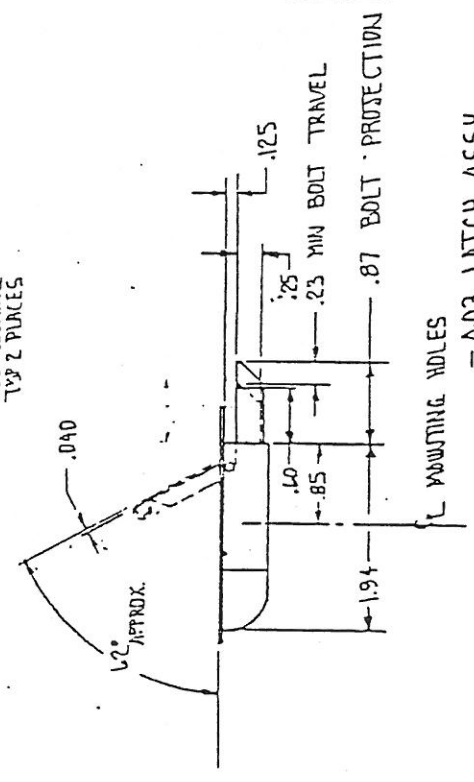

MOUNTING HOLES
-403 LATCH ASSY

-1 BRACKET

- LATCH OPERATION BOLT SPRING LOADED IN THE EXTENDED POSITION; FLAP SPRING LOADED IN THE DOWN POSITION.
 - DECORATIVE FINISH SATIN BRUSH GRAIN DIRECTION AS SHOWN
 - PROTECTIVE FINISH PASSIVATE PER MIL-S-5002
 - MAT'L ALL PARTS CRES 300 SERIES
 - REMOVE ALL SHARP EDGES
- NOTES: UNLESS OTHERWISE SPECIFIED

RECD	PART NUMBER	DESCRIPTION	LIST OF MATERIAL
	-1	BRACKET	BRACKET ONLY
	-403	LATCH ASSY	LATCH ASSY ONLY
	-401	LATCH ASSY	LATCH + MTG BRACKET
			MATERIAL OR NOTE

UNLESS OTHERWISE NOTED DIMENSIONS ARE IN INCHES. TOLERANCES DIM. DECIMALS .XX = .0004 ANGLES DRILLED HOLES PER ANSI B7		CONTRACT NO.
SURFACE ROUGHNESS	HEAT TREAT	DRAFTSMAN
FINISH	INSPECT	CHECKER
REF. NO.	USED ON	ENGINEER
	APPLICATION	PROD. APPD

SKYLOGK INDUSTRIES, INC. SO. EL MONTE, CALIFORNIA	
LATCH ASSY	REY
SIZE CODE IDENT NO. C 51941	A
SCALE 1:1	WT ACT
	SHEET 1 OF 1

2026