

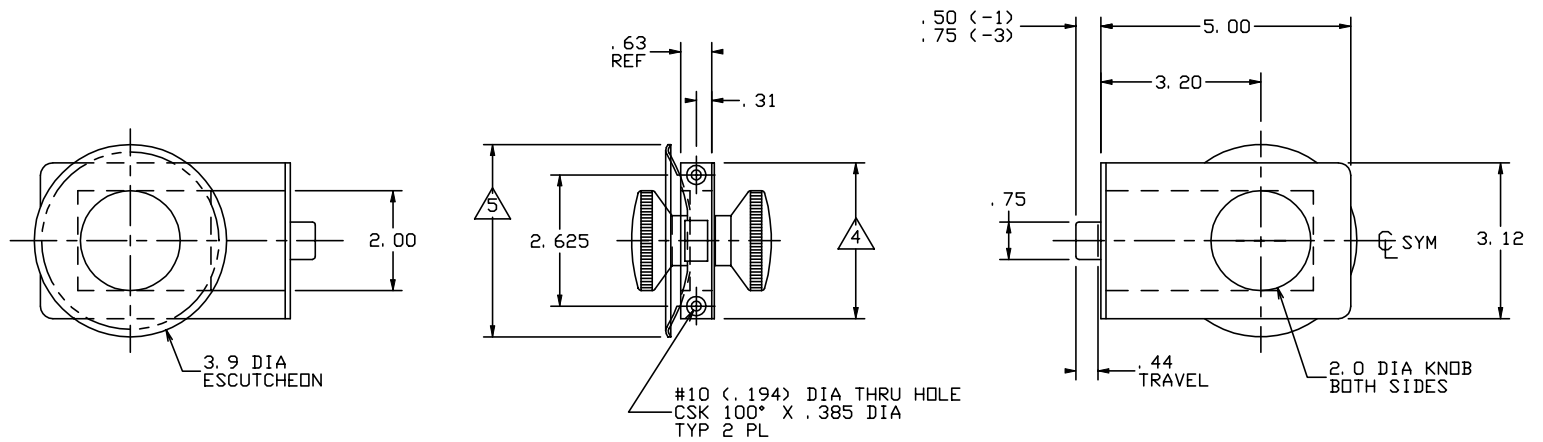

THE INFORMATION AND DESIGN HEREIN WAS ORIGINATED BY AND IS THE PROPERTY OF SKYLOCK INDUSTRIES INCORPORATED. SKYLOCK INDUSTRIES INCORPORATED RESERVES ALL PATENT, PROPRIETARY, DESIGN MANUFACTURING, REPRODUCTION, USE AND SALES RIGHTS THERE TO, AND TO ANY ARTICLE DISCLOSED THEREIN EXCEPT TO THE EXTENT RIGHTS ARE EXPRESSLY GRANTED TO OTHERS. THE FOREGOING DOES NOT APPLY TO VENDOR PROPRIETARY PARTS.

REVISIONS				
ZONE	LTR	DESCRIPTION	DATE	APPROVED
	NC	PRODUCTION RELEASE	8-6-97	T. C.

NOTES: UNLESS OTHERWISE SPECIFIED.

- MATERIAL: CASE ASSY, TURN KNOBS AND ESCUTCHEONS - ALUM. ALLOY.
BOLT AND INTERNAL BUSHINGS - DELRIN
ALL OTHER COMPONENTS - CRES.
- PROTECTIVE FINISH: ALUM. - CLEAR ANODIZE; CRES - PASSIVATE.
- LATCH BOLT IS SPRING LOADED TO THE EXTENDED POSITION. TURNING KNOB ON EITHER SIDE, OR SLAM ACTION RETRACTS BOLT AT ANY TIME.
- DECORATIVE FINISH: POWDER COAT, PANTONE COLOR NO. 422C, FINE TEXTURE, 10% GLOSS.
- DECORATIVE FINISH: POWDER COAT, PANTONE COLOR NO. 16-1406, FINE TEXTURE, 10% GLOSS.



	-3	LATCH ASSY			
	-1	LATCH ASSY			
QTY REQD	PART NO.	DESCRIPTION	MATERIAL	SIZE SPECIFICATION	ITEM NO.
PARTS LIST					
UNLESS OTHERWISE SPECIFIED: DIMENSIONS IN INCHES		DRAWN BY T. C.	8-6-97	 SKYLOCK INDUSTRIES INCORPORATED MONROVIA CALIFORNIA U. S. A.	
TOLERANCES ON DECIMALS .XX ± .01 .XXX ± .030 .XXX ± .010		CHECKED		DOOR LATCH ASSY	
DRILLED HOLES AND 10387		ENGINEER			
		PROJECT			
		APPROVAL			
DO NOT SCALE THIS DRAWING		USED ON	SIZE C	CODE IDENT. NO. 51941	DRAWING NO. 20245
			SCALE 1:2	VT.	SHEET 1 OF 1