

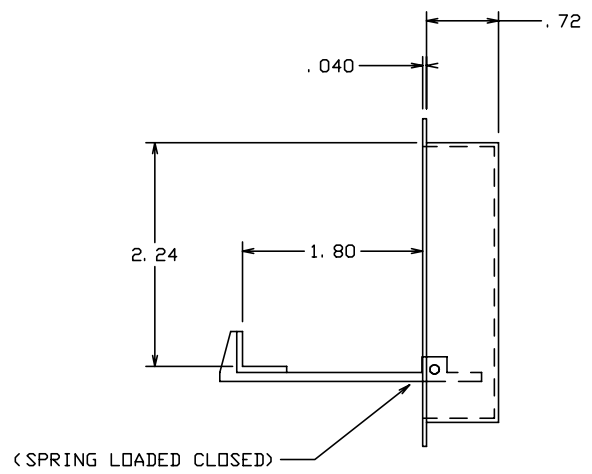

THE INFORMATION AND DESIGN HEREIN WAS ORIGINATED BY AND IS THE PROPERTY OF SKYLOCK INDUSTRIES INCORPORATED. SKYLOCK INDUSTRIES INCORPORATED RESERVES ALL PATENT, PROPRIETARY, DESIGN MANUFACTURING, REPRODUCTION, USE AND SALES RIGHTS THERE TO, AND TO ANY ARTICLE DISCLOSED THEREIN EXCEPT TO THE EXTENT RIGHTS ARE EXPRESSLY GRANTED TO OTHERS. THE FOREGOING DOES NOT APPLY TO VENDOR PROPRIETARY PARTS.

REVISIONS				
ZONE	LTR	DESCRIPTION	DATE	APPROVED
	NC	PRODUCTION RELEASE	10-13-92	T. C.

- NOTES: UNLESS OTHERWISE SPECIFIED.
1. REMOVE ALL BURRS AND BREAK SHARP EDGES.
  2. MAT'L: CASE AND HOOK; 6061-T6 ALUM. ALLOY, SPRING AND PIN; 300 SERIES CRES.
  3. FINISH: ALUM.; SATIN BRUSH AND CLEAR ANODIZE, CRES PARTS; PASSIVATE.

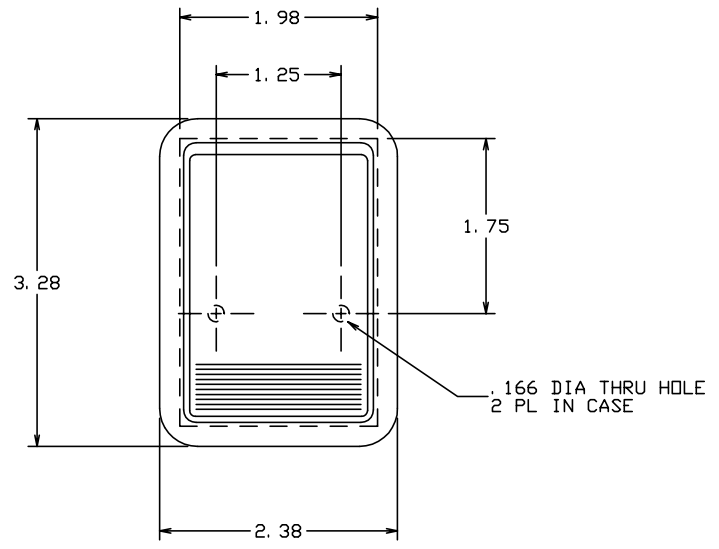

		-1	DOOR HOLD			
QTY REQD	PART NO.	DESCRIPTION		MATERIAL SIZE SPECIFICATION		ITEM NO.
PARTS LIST						
UNLESS OTHERWISE SPECIFIED		DRAWN BY T. CSIK		10-13-92	 SKYLOCK INDUSTRIES INCORPORATED MONROVIA CALIFORNIA U. S. A.	
DIMENSIONS ARE IN INCHES		CHECKED			DOOR HOLD OPEN	
TOLERANCES ON		ENGINEER				
DECIMALS ANGLES DRILLED HOLES		PROJECT				
.X ± .1 ± 0° 30' AND 10387		APPROVAL T. CSIK		10-13-92		
.XX ± .03		APPROVAL				
.XXX ± .010		APPROVAL				
DO NOT SCALE THIS DRAWING		USED ON		SIZE	CODE IDENT. NO.	DRAWING NO.
MATERIAL - FINISH				C	51941	20796
NEXT ASSY				SCALE	2: 1	WT.
FINAL ASSY				SHEET 1 OF 1		REV. NC