

THE INFORMATION AND DESIGN HEREIN WAS OBTAINED BY AND IS THE PROPERTY OF SKYLOCK INDUSTRIES INCORPORATED. SKYLOCK INDUSTRIES INCORPORATED RESERVES ALL PATENT, PROPRIETARY, DESIGN MANUFACTURING INFORMATION, USE AND SALES RIGHTS HEREIN, AND TO ANY ARTICLES DEVELOPED THEREIN EXCEPT TO THE EXTENT RIGHTS ARE EXPRESSLY GRANTED TO OTHERS. THE FOREGOING DOES NOT APPLY TO NON-PATENTED PARTS.

NOTES: UNLESS OTHERWISE SPECIFIED.

1. REMOVE ALL BURRS AND BREAK SHARP EDGES.
2. MAT'L REF.: 'D' HANDLE AND TEE BAR; 6061-T6/T651, ALUM. PER ASTM B-221, OR EQUIV. ALL OTHER PARTS; 300 SERIES CRES., PER AMS-5640N OR EQUIV.
3. FINISH REF.: ALUM.; CLEAR ANODIZE PER MIL-A-8625, TYPE II, CLASS 1. ST. STL.; PASSIVATE PER AMS-QQ-P-35, TYPE II, OR EQUIV.
4. DECORATIVE FINISH REF.: HANDLE AND CUP ARE SATIN BRUSHED ON TOP SURFACES.
5. BOLTING SYSTEM TO BE DETENTED IN ENGAGED AND DISENGAGED POSITIONS.
6. 'D' HANDLE TO BE SPRING LOADED DOWN.
7. PER FAR 45.15. PARTS WILL BE IDENTIFIED WITH:
 1. FAA-PMA.
 2. SKYLOCK IND. INC.
 3. PART NO.
 4. AIRCRAFT ELIGIBILITY.

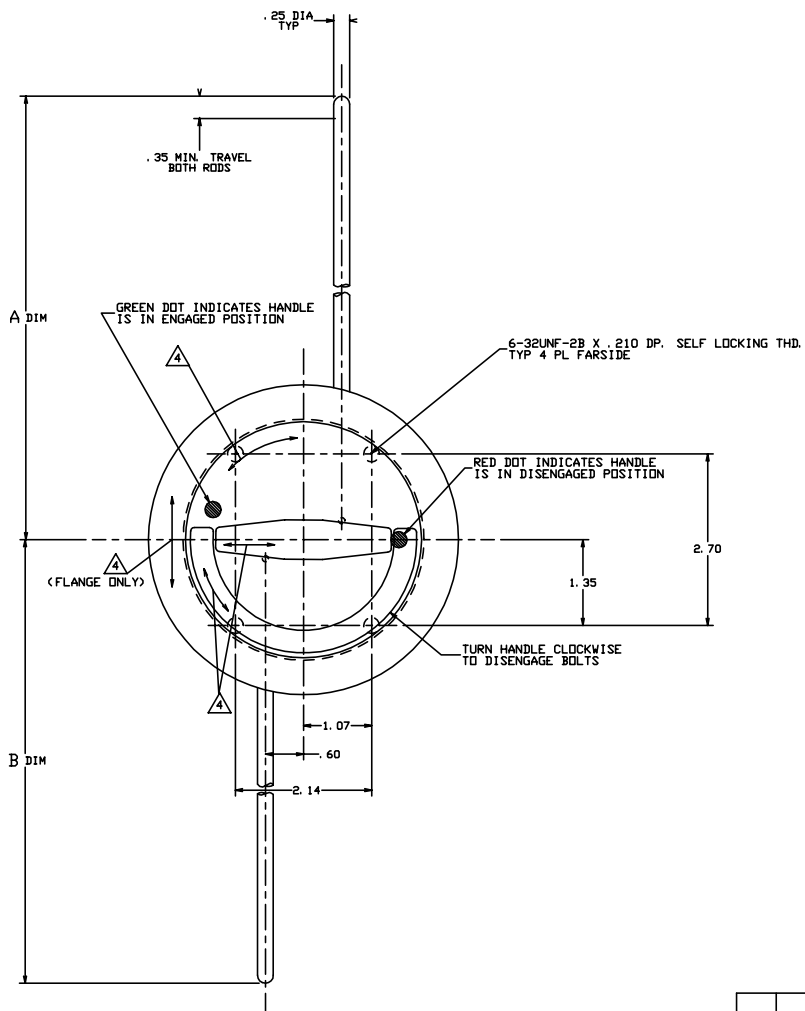

REVISIONS				
ZONE	LTR	DESCRIPTION	DATE	APPROVED
	NC	PRODUCTION RELEASE	8-22-91	T. C.
	A	REVISED NOTE IS 6-32 ... SELF LOCKING THD.	9-26-91	T. C.
	B	SEE ECN B	3/31/99	T. C.

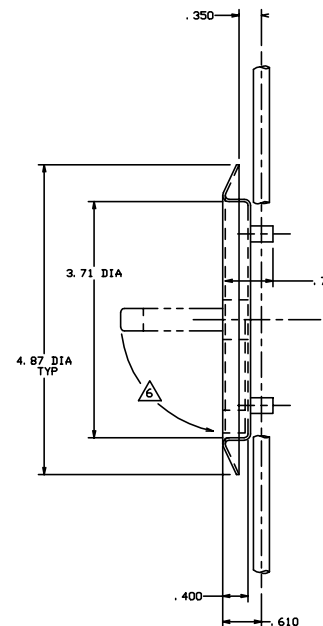

SEE TABULATION BLOCK FOR ORDERING INFORMATION

QTY REQD	PART NO.	DESCRIPTION	MATERIAL	SIZE	SPECIFICATION	MAKE FROM
	-402	BOLTING SYSTEM	<DPP. -401>			120719-402
	-401	BOLTING SYSTEM	<SHOWN>			120719-401
PARTS LIST						
UNLESS OTHERWISE SPECIFIED		DRAWN BY	T. CSIK	9-13-91	SKYLOCK INDUSTRIES INCORPORATED MONROVIA CALIFORNIA	
DIMENSIONS ARE IN INCHES		CHECKED	L. GARCIA	3/18/99		
TOLERANCES ON		ENGINEER	T. CSIK	3/18/99		
DECIMALS		DRAWN	P. MATSUOKA	3/18/99		
ANGLES		INSP	J. VIVIRITO	3/18/99	2 POINT DOOR BOLTING SYSTEM	
DRILLED HOLES		QC				
Holes 1/8" to 1/2" 3/16" and 1/8" 1/16" and 1/8"						
DO NOT SCALE THIS DRAWING						
MATERIAL - FINISH		USED ON		SIZE	CODE IDENT. NO.	DRAWING NO.
				D	51941	20719
NEXT ASBY				SCALE	1:1	REV. B
MANUFACTURE IN ACCORDANCE WITH SKYLOCK IND. INC., QUALITY CONTROL MANUAL, QC 001						
				SCALE	1:1	SHEET 1 OF 1

EXAMPLE:

20719-401-100-100

A DIM. @ 10.0 INCHES
B DIM. @ 10.0 INCHES

	FIRST TWO DIGITS (INCHES) THIRD DIGIT (TENTH IN.) A DIM.	FIRST TWO DIGITS (INCHES) THIRD DIGIT (TENTH IN.) B DIM.
-402		
-401		
FIRST DASH NO.	SECOND DASH NO.	THIRD DASH NO.
TABULATION BLOCK		