

THE INFORMATION AND DESIGN HEREIN WAS ORIGINATED BY AND IS THE PROPERTY OF SKYLOCK INDUSTRIES INCORPORATED. SKYLOCK INDUSTRIES INCORPORATED RESERVES ALL PATENT, PROPRIETARY, DESIGN MANUFACTURING, REPRODUCTION, USE AND SALES RIGHTS THEREOF, AND TO ANY ARTICLE DISCLOSED THEREIN EXCEPT TO THE EXTENT RIGHTS ARE EXPRESSLY GRANTED TO OTHERS. THE FOREGOING DOES NOT APPLY TO VENDOR PROPRIETARY PARTS.

NOTES: UNLESS OTHERWISE SPECIFIED

1. REMOVE ALL BURRS AND SHARP EDGES
2. MAT'L: TURN; ALUM ALLOY;  
CAM; 300 SERIES CRES
3. FINISH: TURN; BRIGHT BUFF AND CANDY APPLE RED ANODIZE (-401 THRU -417).  
SATIN BRUSH AND CLEAR ANODIZE (-419, -421, -423)
4. ROTATION: 90° LEFT OR RIGHT HAND

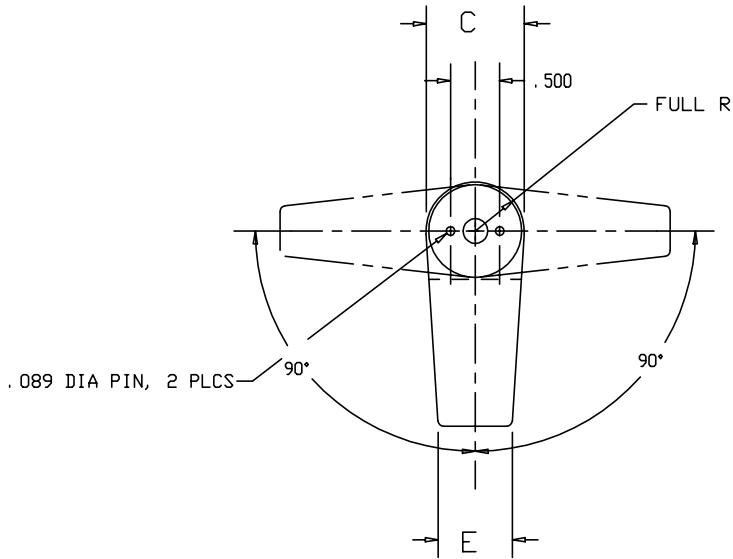

-401, -403 1/4 TURN RETAINER

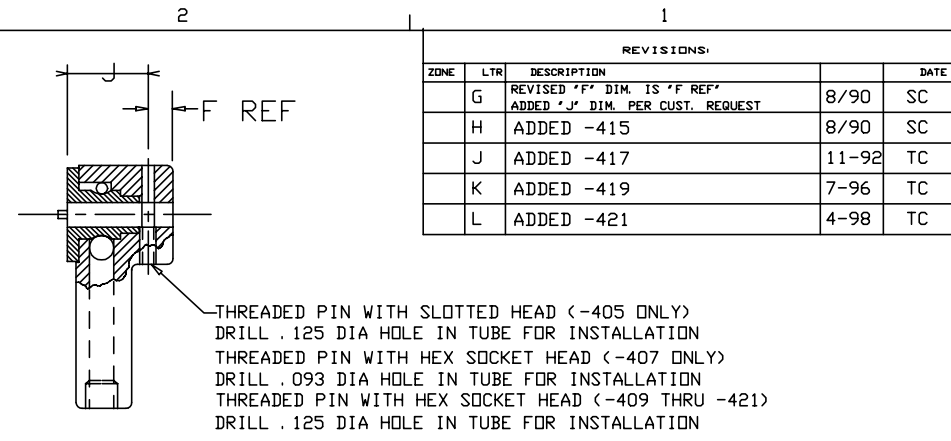

-405 THRU -421 SHOWN (SAME AS -401 AND -403 EXCEPT AS NOTED)

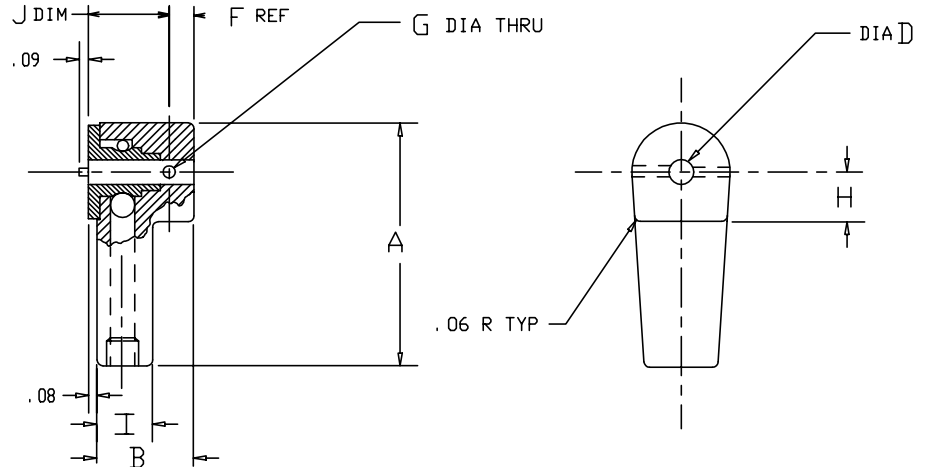

REVISIONS				
ZONE	LTR	DESCRIPTION	DATE	SC
G		REVISED 'F' DIM. IS 'F REF' ADDED 'J' DIM. PER CUST. REQUEST	8/90	SC
H		ADDED -415	8/90	SC
J		ADDED -417	11-92	TC
K		ADDED -419	7-96	TC
L		ADDED -421	4-98	TC

QTY REQ'D	PART / IDENT NO.	DESCRIPTION	MATERIAL / SPECIFICATION	ITEM NO.
	-421	RETAINER		
	-419	RETAINER		
	-417	RETAINER		
	-415	RETAINER		
	-413	RETAINER		
	-411	RETAINER		
	-409	RETAINER		
	-407	RETAINER		
	-405	RETAINER		
	-403	RETAINER		
	-401	RETAINER		

DASH NO.	A	B	C	D	E	F	G	H	I	J
-401	2.50	1.00	1.00	.252	.75	.25	.125	.50	.56	.810/ .830
-403	1.50	.84	.62	.189	.50	.22	.093	.31	.50	.680/ .700
-405	2.25	1.00	.75	.252	.75	.25	/	.375	.50	.810/ .830
-407	1.50	.84	.62	.189	.50	.14	/	.31	.50	.760/ .780
-409	2.50	1.00	1.00	.252	.75	.22	/	.50	.56	.840/ .860
-411, -421	2.50	1.00	.75	.252	.50	.22	/	.50	.56	.840/ .860
-413	5.00	2.00	.75	.252	.75	.50	/	3.00	1.00	1.560/ 1.580
-415	2.50	1.00	.75	.252	.50	.22	/	.50	.25	.840/ .860
-417	2.50	1.00	.75	.252	.50	.22	/	.50	.50	.840/ .860
-419	2.25	1.00	.75	.252	.50	.22	/	.50	.56	.840/ .860

UNLESS OTHERWISE SPECIFIED DIMENSIONS ARE IN INCHES		CONTRACT NO.		SKYLOCK INDUSTRIES INCORPORATED MONROVIA, CALIFORNIA, USA
DECIMALS .XX .XXX	TOLERANCES .00 .010	ANGULAR 0 30'	DATE 8/90	
NEXT ASSY		DRAWN BY SC		1/4 TURN RETAINER
FINAL ASSY		CHECK		
USED ON		DESIGN SC		SIZE C
FINISH		DESIGN ACTIVITY		
ACT WT		CUSTOMER		FSC# NL 51941
CALC WT		DATE 8/21/90		DRAWING NO. 20682
		SCALE NONE		REV. L
		SHEET 1 OF 1		