

4

3

2

1

THE INFORMATION AND DESIGN HEREIN WAS ORIGINATED BY AND IS THE PROPERTY OF SKYLOCK INDUSTRIES INCORPORATED. SKYLOCK INDUSTRIES INCORPORATED RESERVES ALL PATENT, PROPRIETARY, DESIGN MANUFACTURING, REPRODUCTION, USE AND SALES RIGHTS THERE TO, AND TO ANY ARTICLE DISCLOSED THEREIN EXCEPT TO THE EXTENT RIGHTS ARE EXPRESSLY GRANTED TO OTHERS. THE FOREGOING DOES NOT APPLY TO VENDOR PROPRIETARY PARTS.

REVISIONS				
ZONE	LTR	DESCRIPTION	DATE	APPROVED
	NC	PRODUCTION RELEASE	3-21-89	S. CSIK
	A	REDRAWN	6-5-96	T. CSIK
	B	NOTE IS MS33656-4 WAS MS33656-3, TO AGREE WITH DRAWING PRIOR TO REV. A	6-25-98	T. CSIK
	C	SEE ECN C	9/14/99	E. WELSH

NOTES: UNLESS OTHERWISE SPECIFIED.

1. MAT'L: 303 CRES COND. A, PER AMS-5640N OR EQUIV.
2. DECORATIVE FINISH: SATIN NICKEL PLATE.
- 3 WITH HANDLE LOCKED IN UPRIGHT POSITION.
4. APPLICABLE TO FAA-PMA REPLACEMENT OR MODIFICATION PARTS ONLY. PER FAR 45.15, PARTS WILL BE IDENTIFIED WITH:
 1. FAA-PMA.
 2. SKYLOCK IND. INC.
 3. PART NO.
 4. AIRCRAFT INSTALLATION ELIGIBILITY.

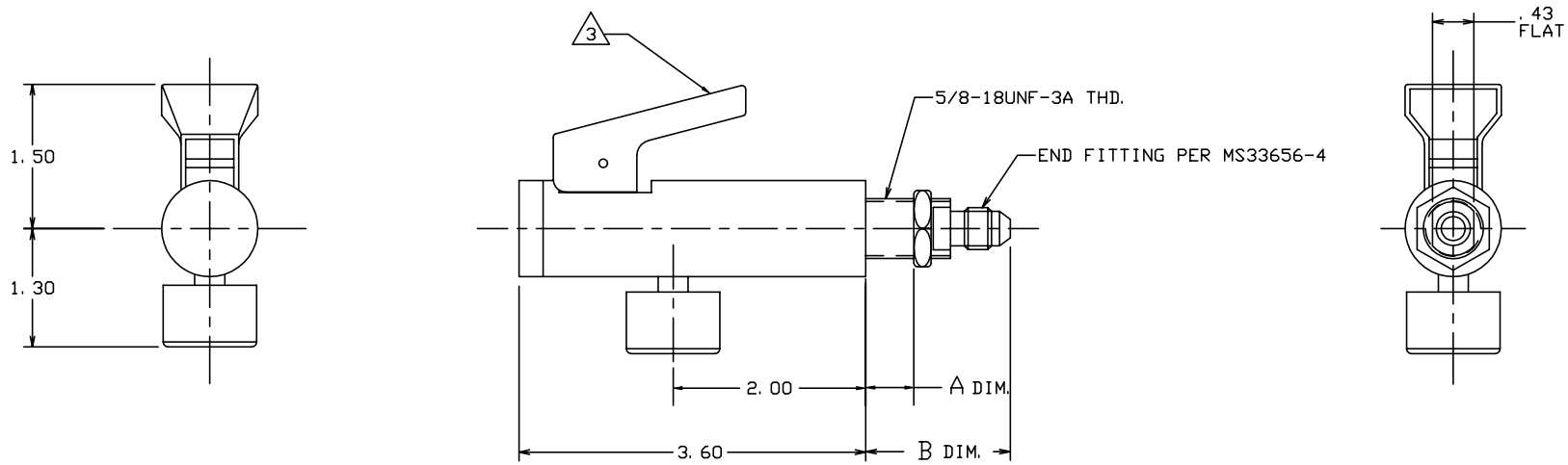

-401, -403, -405 SPIGOT ASSY

2.20	1.00	-405	SPIGOT ASSY		
1.95	.75	-403	SPIGOT ASSY		
1.70	.50	-401	SPIGOT ASSY		
B DIM	A DIM	PART NO.	DESCRIPTION	MATERIAL	SIZE SPECIFICATION

PARTS LIST

UNLESS OTHERWISE SPECIFIED	DRAWN BY	S. CSIK	3-21-89	 SKYLOCK INDUSTRIES INCORPORATED MONROVIA CALIFORNIA U. S. A.
DIMENSIONS ARE IN INCHES	CHECKED	E. WELSH	9/13/99	
TOLERANCES ON	ENGINEER	E. WELSH	9/14/99	
DECIMALS ANGLES DRILLED HOLES	MFG	P. MATSUOKA	9/16/99	
.X ± .1 ± 0° 30' AND 10387	QC	J. VIVIRITO	9/16/99	
.XX ± .03				
.XXX ± .010				

DO NOT SCALE THIS DRAWING

MATERIAL - FINISH USED ON

NEXT ASSY

FINAL ASSY

SIZE **C** CODE IDENT. NO. **51941** DRAWING NO. **90044** REV. **C**

SCALE 1/1 WT. SHEET 1 OF 1

FLUID MEDIA	TYPE	OPERATING PRESSURE	OPERATING TEMP.	FLOW
POTABLE WATER	SELF VENTING & BLEEDING	0-125 PSIG	35°F TO 225°F	70 OZ. /MIN. AT 70°F AND 30 P. S. I. INLET PRESSURE

4

3

2

1