

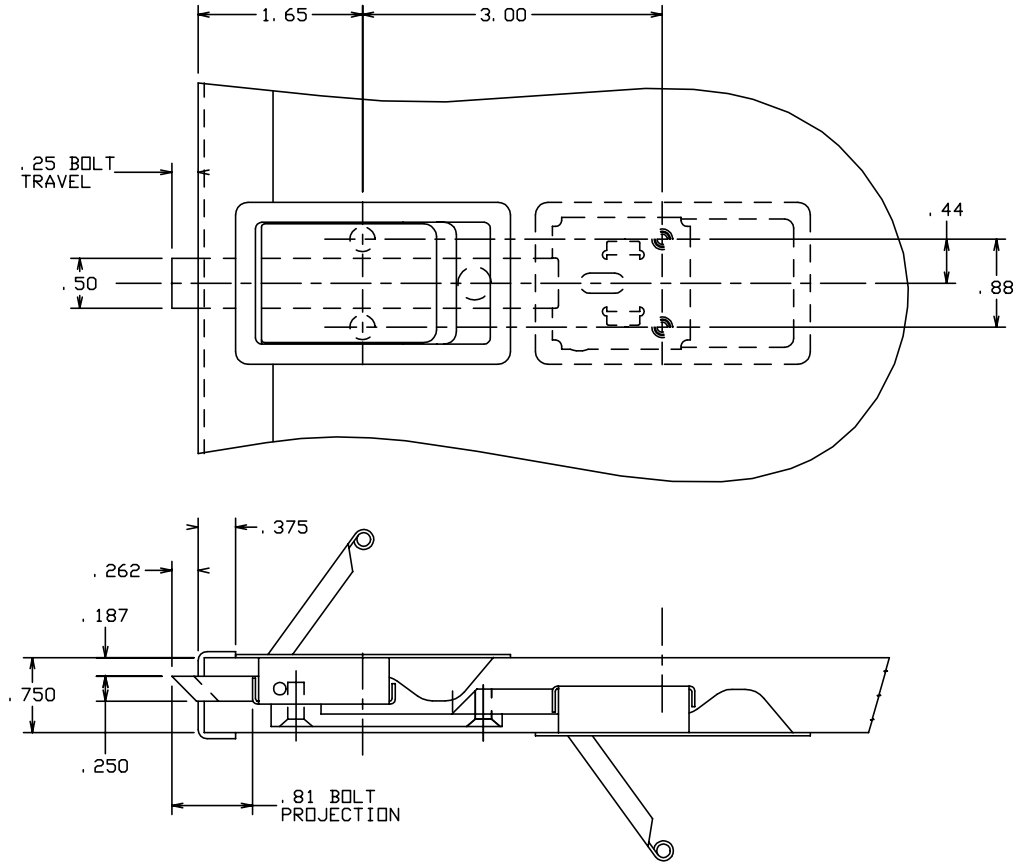

THE INFORMATION AND DESIGN HEREIN WAS ORIGINATED BY AND IS THE PROPERTY OF SKYLOCK INDUSTRIES INCORPORATED. SKYLOCK INDUSTRIES INCORPORATED RESERVES ALL PATENT, PROPRIETARY, DESIGN MANUFACTURING, REPRODUCTION, USE AND SALES RIGHTS THERE TO, AND TO ANY ARTICLE DISCLOSED THEREIN EXCEPT TO THE EXTENT RIGHTS ARE EXPRESSLY GRANTED TO OTHERS. THE FOREGOING DOES NOT APPLY TO VENDOR PROPRIETARY PARTS.

REVISIONS				
ZONE	LTR	DESCRIPTION	DATE	APPROVED
	NC	PRODUCTION RELEASE	9-14-92	T. CSIK

NOTES: UNLESS OTHERWISE SPECIFIED,

1. REMOVE ALL BURRS AND BREAK SHARP EDGES.
2. MAT'L: ALL COMP'S: 300 SERIES CRES.
3. FINISH: PASSIVATE.
4. DECORATIVE FINISH: SATIN BUFF TOP OF CASE AND HANDLE.
5. STATIC LOAD: 600 LBS. MAX.
6. BOLT IS SPRING LOADED AND ALWAYS FREE TO LATCH.
7. HANDLE IS SPRING LOADED OPEN WHEN BOLT IS NOT PROPERLY ENGAGED.



-401		LATCH ASSY			
PART NO.	DESCRIPTION	MATERIAL	SIZE	SPECIFICATION	ITEM NO.
PARTS LIST					
UNLESS OTHERWISE SPECIFIED		DRAWN BY	T. CSIK	9-14-92	 SKYLOCK INDUSTRIES INCORPORATED MONROVIA CALIFORNIA U. S. A.
DIMENSIONS ARE IN INCHES		CHECKED			
TOLERANCES ON		ENGINEER			
DECIMALS ANGLES DRILLED HOLES		PROJECT			
.X ± .1 ± 0° 30' AND 10387		APPROVAL	T. CSIK	9-14-92	LATCH ASSEMBLY
.XX ± .03		APPROVAL			
.XXX ± .010		DO NOT SCALE THIS DRAWING			
MATERIAL - FINISH	USED ON	SIZE	CODE IDENT. NO.	DRAWING NO.	REV.
NEXT ASSY		C	51941	20793	NC
FINAL ASSY		SCALE	1: 1	WT.	SHEET 1 OF 1