

THE INFORMATION AND DESIGN HEREIN WAS ORIGINATED BY AND IS THE PROPERTY OF SKYLOCK INDUSTRIES INCORPORATED. SKYLOCK INDUSTRIES INCORPORATED RESERVES ALL PATENT, PROPRIETARY, DESIGN MANUFACTURING, REPRODUCTION, USE AND SALES RIGHTS THEREON, AND TO ANY ARTICLE DISCLOSED THEREIN EXCEPT TO THE EXTENT RIGHTS ARE EXPRESSLY GRANTED TO OTHERS. THE FOREGOING DOES NOT APPLY TO VENDOR PROPRIETARY PARTS.

REVISIONS				
ZONE	LTR.	DESCRIPTION	DATE	APPROVED
	C	REDRAW AND REVISE	4.19.90	SC

NOTES: UNLESS OTHERWISE SPECIFIED

1. REMOVE ALL BURRS AND SHARP EDGES
2. MAT'L: 2024-T3 ALUM ALLOY
3. FINISH: TURN; BRIGHT POLISH AND CANDY APPLE RED ANODIZE; BLOCK ASSY; SATIN BRUSH AND CLEAR ANODIZE; CRES PARTS- PASSIVATE
4. ROTATION: 180°, DETENTED EVERY 90°

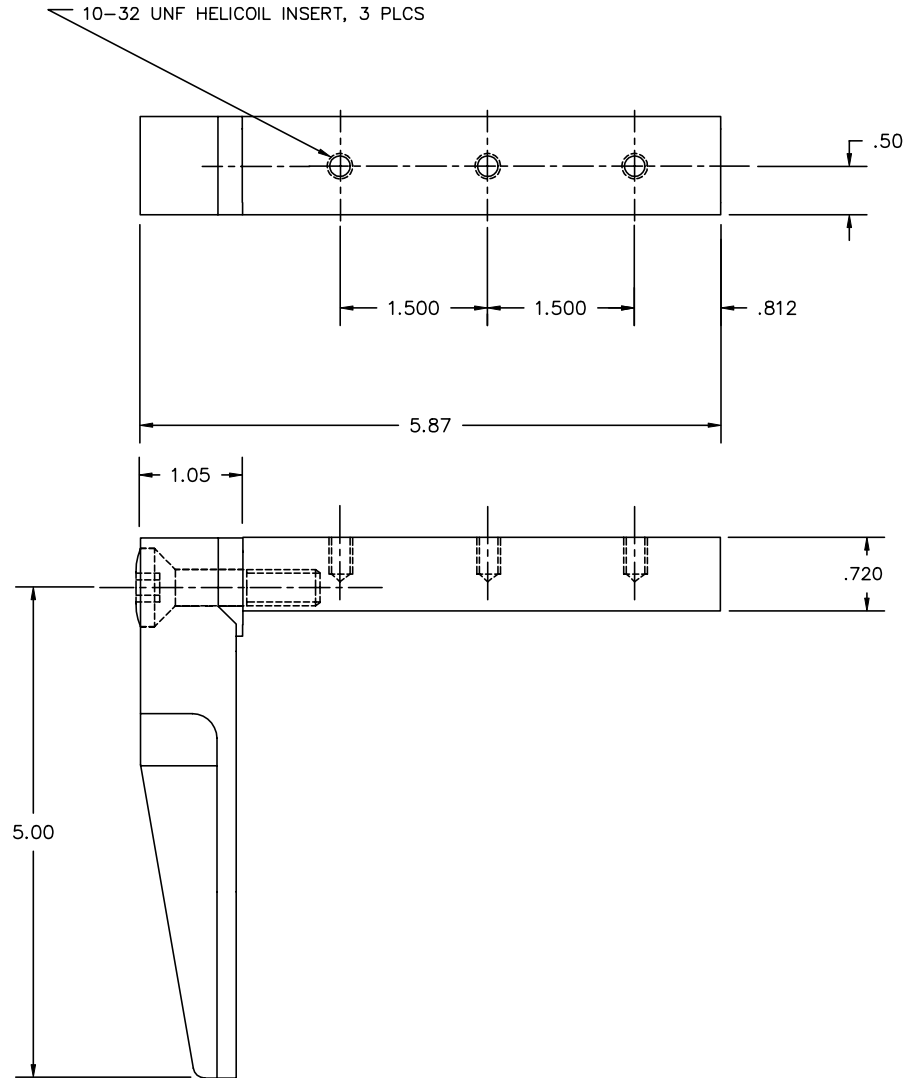
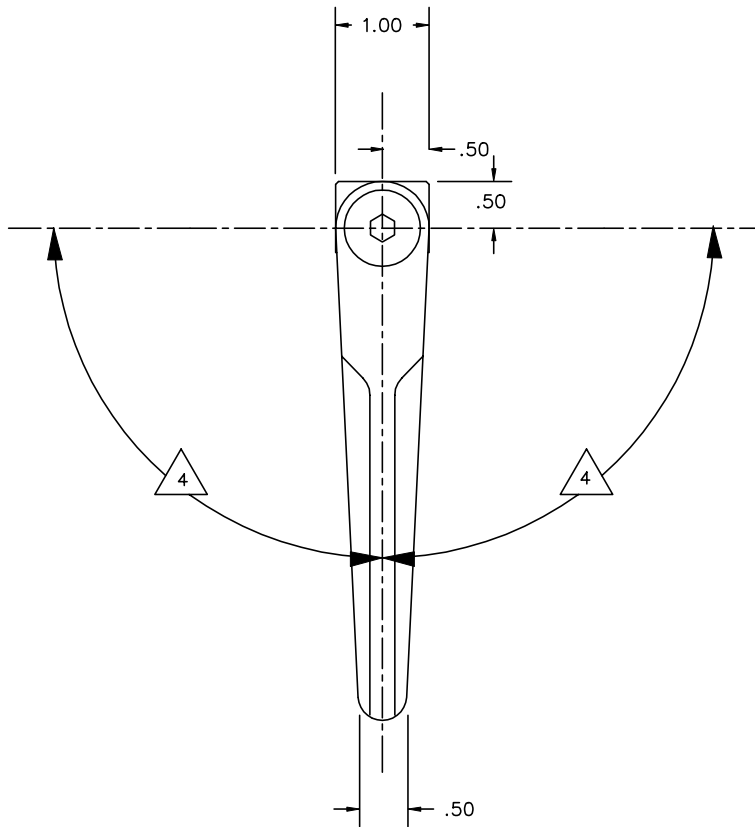

		-401	RETAINER ASSY		
QTY. REQ'D	PART / IDENT NO.	DESCRIPTION	MATERIAL / SPECIFICATION	ITEM NO.	
UNLESS OTHERWISE SPECIFIED: DIMENSIONS ARE IN INCHES		CONTRACT NO.	 SKYLOCK INDUSTRIES INCORPORATED MONROVIA, CALIFORNIA, USA		
TOLERANCES DECIMALS .XX ±.03 .XXX ±.010 DO NOT SCALE DRAWING		CUSTOMER			
		DRAWN BY	RETAINER ASSY		
		CHECK			
NEXT ASSY	FINAL ASSY	DESIGN			
		S.CSIK			
USED ON	DESIGN ACTIVITY		SIZE	FSCM NO.	DRAWING NO.
			C	51941	20650
FINISH	ACT WT	CALC WT	SCALE	RELEASE DATE	SHEET
			1/1	4.19.90	1 OF 1

DRAWING NO. SHEET OF