

PAOLO ASTORI s.r.l.
via Mirabella 9-MAGGIATE SUP.
I 28013-GATTICO (NO)

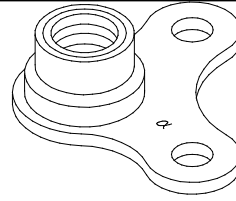

PO350
PO351

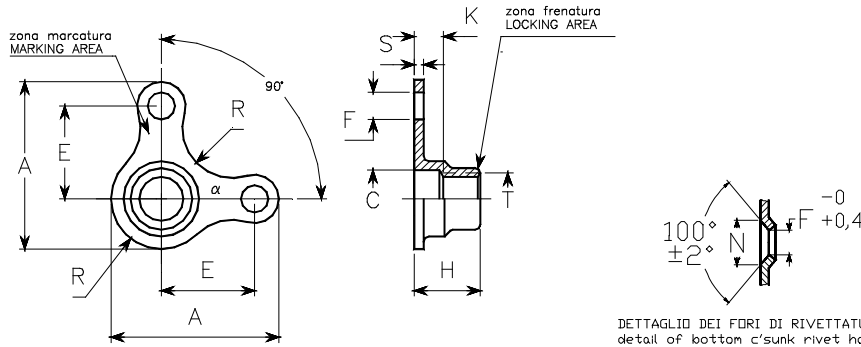

DETTAGLIO DEI FORI DI RIVETTATURA SVASATI
detail of bottom c'sunk rivet holes

dimensioni in mm. dimensions in mm.

codice dimensioni dimensions code	filettatura thread T	tolleranz a tolerance	A max.	C min.	E ±0,1	F 0 +0,2	H max.	K min.	N ±0,25	R max.	S max.	massa (kg x 1000) mass (kg x 1000)
50	5/16-24 UNJF	3B	19,3	8,1	9,12	3,3	8,4	1,6	5,8	6,5	1,65	3,0

cod. materiali material code	materiale material	finitura finish	durezza HR _C hardness HR _C	classe resistenza strenght class	classe temperatura temperature class
PO350L	W1.7214.4 acciaio-steel	cadmiatura+MoS ₂ cadmium plating+MoS ₂	43 max.	900 MPa	235°C
PO350C	25CrMo4	cadmiatura cadmium plating			235°C
PO351X	W1.4944.4 lega A286 A286 alloy	passivazione passivation	27 min.		425°C
PO351L		passivazione+MoS ₂ + puntino verde passivation+MoS ₂ + green dot			315°C
PO351A		argentatura silver plating			425°C

FILETTO: profilo MIL-S-8879.
MARCATURA: simbolo α del costruttore.
NORMA di costruzione e controllo: NASM25027.
DESIGNAZIONE ASTORI: codice materiali-codice dimensioni.
Esempio: PO350C-5 indica una olivetta a disegno PO350, in acciaio cadmiato, filettatura 5/16 UNJF-3B
VARIAZIONI: aggiungere una K al codice dimensioni per le olivette con i fori di rivettatura svasati.

THREAD: profile MIL-S-8879.
MARKING: manufacturer symbol α
PROCUREMENTS specification NASM25027.
ASTORI CALL OUT: materials code-dimensions code.
Example: PO350C-5 designates a plate nut according to PO350 drawing, in steel, cadmium plated, with 5/16 UNJF-3B thread.
VARIATIONS: add a K to dimensions code for plate nuts with countersunk rivet holes.

Reference	OLIVETTA AUTOFRENANTE, MINIATURA AD ANGOLO 90°, FISSA, FILETT. POLLICI ANCHOR NUT, SELF-LOCKING, MINIATURE CORNER 90°, FIXED, INCH THREAD	PO350 PO351
-----------	--	------------------------------