

THE INFORMATION AND DESIGN HEREIN WAS ORIGINATED BY AND IS THE PROPERTY OF SKYLOCK INDUSTRIES INCORPORATED. SKYLOCK INDUSTRIES INCORPORATED RESERVES ALL PATENT, PROPRIETARY, DESIGN MANUFACTURING, REPRODUCTION, USE AND SALES RIGHTS THERE TO, AND TO ANY ARTICLE DISCLOSED THEREIN EXCEPT TO THE EXTENT RIGHTS ARE EXPRESSLY GRANTED TO OTHERS. THE FOREGOING DOES NOT APPLY TO VENDOR PROPRIETARY PARTS.

REVISIONS				
ZONE	LTR	DESCRIPTION	DATE	APPROVED
	E	SEE ECN E	1/18/99	T. CSIK
	F	SEE ECN F	7/12/99	E. WELSH
	G	SEE ECN G	10/21/99	T. CSIK

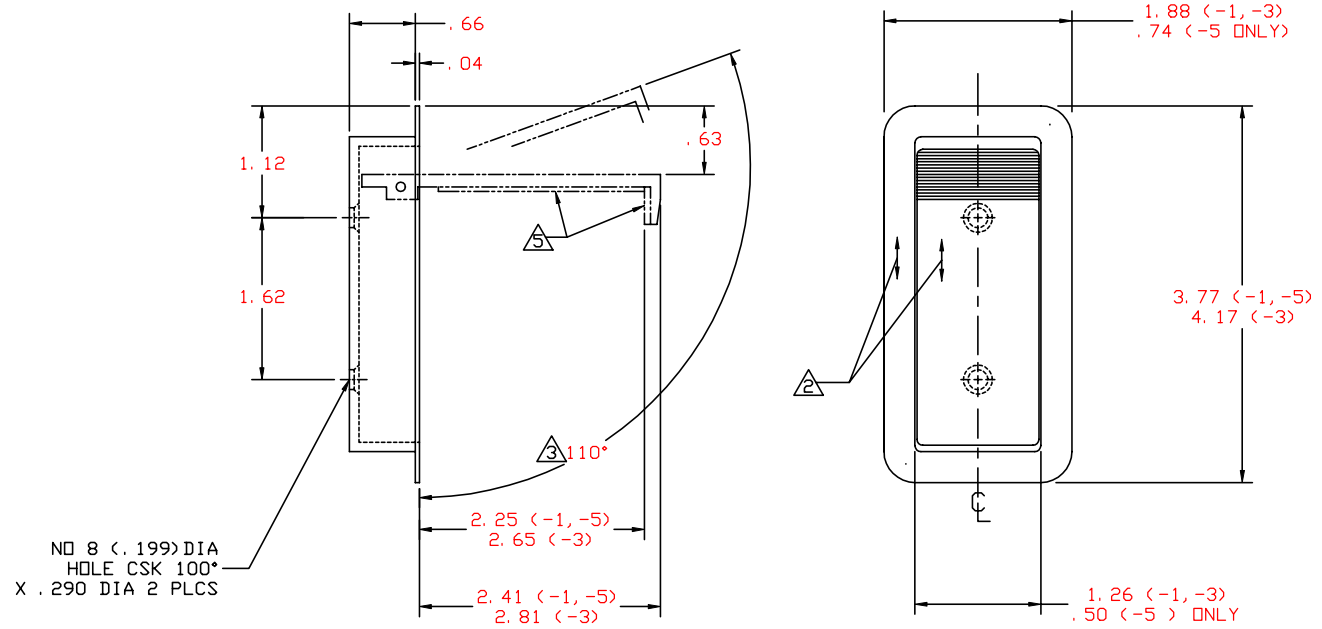

11. APPLICABLE TO FAA-PMA REPLACEMENT OR MODIFICATION PARTS ONLY. PER FAR 45.15, PARTS WILL BE IDENTIFIED WITH:
1. FAA-PMA.
 2. SKYLOCK IND. INC.
 3. PART NO.
 4. AIRCRAFT INSTALLATION ELIGIBILITY.

△ ADHESIVE BACK CORK.

4. PANEL CUTOUT: 1.50 X 3.42. (-1);
 .74 X 3.42. (-5);
 1.50 X 3.82 (-3).

△ HOOK IS SPRING-LOADED CLOSED.

△ REFERENCE FINISH: ALUM. PARTS; SATIN BUFF & CLEAR ANODIZE PER MIL-A-8625, TYPE II, CLASS I.
 CRES PARTS: PASSIVATE PER AMS-QQ-P-35, TYPE II.

1. REFERENCE MAT'L: CASE & HOOK; ALUM. ALLOY PER ASTM B-221 OR EQUIV. ALL OTHER PARTS; 300 SERIES CRES COND. A, PER ASTM-A-240 OR EQUIV.

REMOVE ALL BURRS AND SHARP CORNERS.

NOTES: UNLESS OTHERWISE SPECIFIED.

		-5	DOOR HOLD OPEN		120352-5
		-3	DOOR HOLD OPEN		120352-3
		-1	DOOR HOLD OPEN		120352-1
QTY REQD	PART NO.	DESCRIPTION	MATERIAL OR NOTE	MAKE FROM	

PARTS LIST					
UNLESS OTHERWISE SPECIFIED	DRAWN BY	JEE	12/18/80	SKYLOCK INDUSTRIES INCORPORATED MONROVIA CALIFORNIA U. S. A.	DOOR HOLD OPEN
DIMENSIONS ARE IN INCHES	CHECKED	DEAN VO	12/30/98		
TOLERANCES ON	ENGINEER	T. CSIK	12/31/98		
DECIMALS ANGLES DRILLED HOLES	MFG	P. MATSUOKA	1/6/99		
.X ± .1 ± 0° 30' AND 10387	QC	J. VIVIRITO	1/12/99		
.XXX ± .010					
SURFACE ROUGHNESS					
DO NOT SCALE THIS DRAWING	USED ON			SIZE	CODE IDENT. NO. DRAWING NO. REV.
MATERIAL - FINISH				C	51941 20352 G
MANUFACTURE IN ACCORDANCE WITH SKYLOCK IND. INC. QUALITY CONTROL MANUAL QC.001			SCALE	1: 1	VT. SHEET 1 OF 1