

THE INFORMATION AND DESIGN HEREIN WAS ORIGINATED BY AND IS THE PROPERTY OF SKYLARK INDUSTRIES INCORPORATED. SKYLARK INDUSTRIES INCORPORATED RESERVES ALL PATENT, PROPRIETARY, DESIGN MANUFACTURING INFORMATION, AND SALES RIGHTS HEREIN, AND TO ANY ARTICLE REPRODUCED THEREIN EXCEPT TO THE EXTENT RIGHTS ARE EXPRESSLY GRANTED TO OTHERS. THE FOREGOING DOES NOT APPLY TO NON-PATENTABLE MATTER.

REVISIONS:				
ZONE	LIN	DESCRIPTION	DATE	APPROVED
	NC	PRODUCTION RELEASE	5-14-92	SC
	A	ADDED -405	10-4-93	TC
	B	ADDED -407	9-28-98	TC
	C	SEE ECN C		

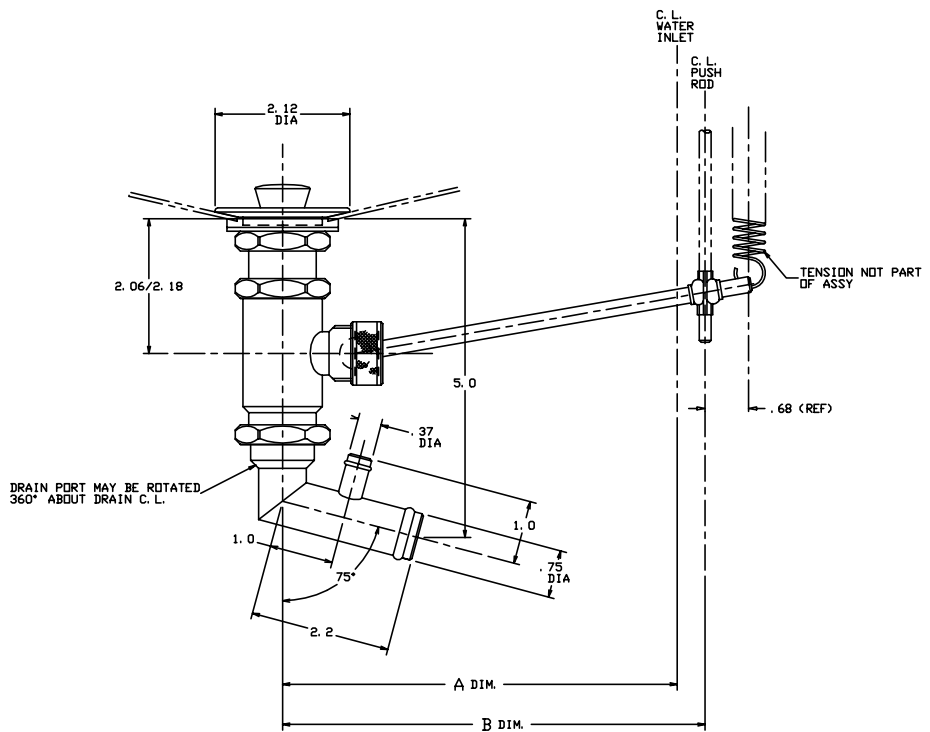

-405 DRAIN ASSY SHOWN

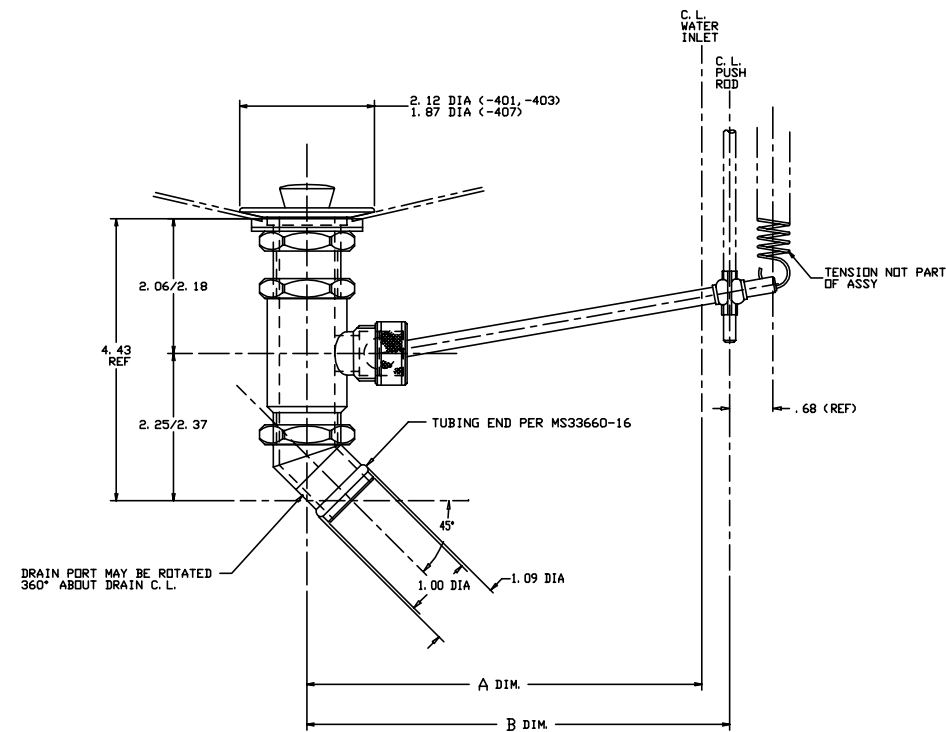

-401, -403, -407 DRAIN ASSY
-407 S/A -403 EXCEPT FLANGE

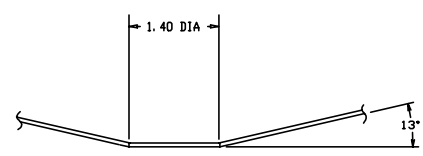

SINK-DRAIN CUTOUT

- PER FAR 45.15, PARTS WILL BE IDENTIFIED WITH:
 - FAA-PMA
 - SKYLARK IND. INC.
 - PART NO.
 - AIRCRAFT ELIGIBILITY.
- FINISH: ALL VISIBLE SURFACES SHALL BE SATIN BRUSHED
- MAT'L REF.: SINK FLANGE, BODY, DRAIN TUBE, ACTUATING ROD, AND POPPET; 302/304 CRES, COND. A, PER ASTM-A240, OR EQUIV. SEALS AND GASKETS; NEOPRENE, SHORE A DUREMETER, OR EQUIV. ACTUATING BALL AND HOUSING; NYLON 6/6 PER ASTM D-4066-PA 114, OR EQUIV.

1. REMOVE ALL BURRS AND SHARP EDGES
NOTES: UNLESS OTHERWISE SPECIFIED

7.29	6.85		-407	DRAIN ASSY		120736-407
7.29	6.85		-405	DRAIN ASSY	(WITH OVERFLOW CONNECTOR)	120736-405
7.29	6.85		-403	DRAIN ASSY		120736-403
3.25	2.81		-401	DRAIN ASSY		120736-401
B	A			PART NO.	DESCRIPTION	MAKE FROM
UNLESS OTHERWISE SPECIFIED		DRAWN BY S. CSIK		10-4-91		 SKYLARK INDUSTRIES INCORPORATED HANOVERIA, CALIFORNIA
DIMENSIONS ARE IN INCHES		CHECKED				
TOLERANCES ON DECIMALS		ANGLES		DRILLED HOLES		20736 DRAIN
: .015		: 30°		: .001		
: .001		: .001		: .001		
DO NOT SCALE THIS DRAWING		USED ON		SCALE		
MATERIAL - FINISH		CODE IDENT. NO.		DRAWING NO.		REV. C
NEXT ASSY		D 51941		20736		
MANUFACTURE IN ACCORDANCE WITH SKYLARK IND. INC., QUALITY CONTROL MANUAL QC 001		SCALE 1:1		SHEET 1 OF 1		