

THE INFORMATION AND DESIGN HEREIN WAS ORIGINATED BY AND IS THE PROPERTY OF SKYLOCK INDUSTRIES INCORPORATED. SKYLOCK INDUSTRIES INCORPORATED RESERVES ALL PATENT, PROPRIETARY, DESIGN MANUFACTURING, REPRODUCTION, USE AND SALES RIGHTS THERE TO, AND TO ANY ARTICLE DISCLOSED THEREIN EXCEPT TO THE EXTENT RIGHTS ARE EXPRESSLY GRANTED TO OTHERS. THE FOREGOING DOES NOT APPLY TO VENDOR PROPRIETARY PARTS.

REVISIONS				
ZONE	LTR	DESCRIPTION	DATE	APPROVED
	G	FINISH WAS SATIN NICKEL PLATE.	6-5-98	TC
	H	SEE ECN H	3/9/99	TC
	J	SEE ECN J	3/26/99	TC
	K	SEE ECN K		

FLUID MEDIA	TYPE	OPERATION PRESS.	OPERATION TEMP.	FLOW
POTABLE WATER	SELF VENTING/ BLEEDING (-405,-409,-411) NON-VENTING/NON-BLEEDING (-403,-407)	0 - 120 P.S.I.	35° - 225° F	100/140 FL. OZ./MIN. AT 70° F 30 P.S.I. INLET PRESS.
POTABLE WATER	NON-VENTING/NON-BLEEDING (-413)	0 - 120 P.S.I.	35° - 225° F	50/60 FL. OZ./MIN. AT 70° F 24-30 P.S.I. INLET PRESS.

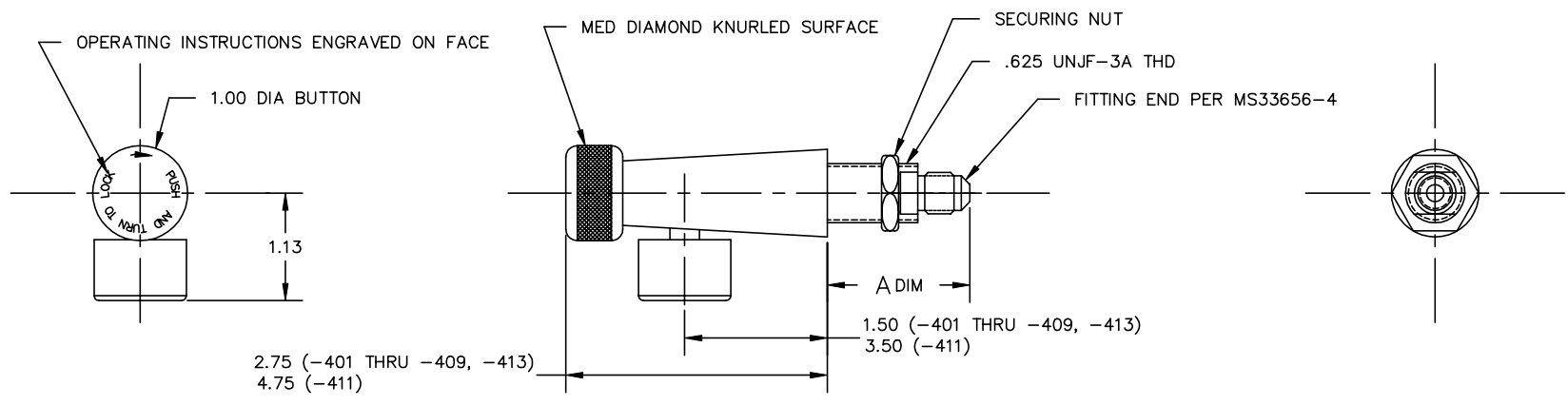

-401 THRU -413 SPIGOT

- APPLICABLE TO FAA-PMA REPLACEMENT OR MODIFICATION PARTS ONLY. PER FAR 45.15, PARTS WILL BE IDENTIFIED WITH:
    1. FAA-PMA.
    2. SKYLOCK IND. INC.
    3. PART NO.
    4. AIRCRAFT INSTALLATION ELIGIBILITY.
  - MOUNTING STYLE: BULKHEAD
  - OPERATION: CONTINUOUS FLOW; PUSH AND TURN BUTTON TO LOCKED POSITION; RELEASE OF BUTTON FROM LOCKED POSITION WILL STOP FLOW; INTERMITTENT FLOW; PUSH BUTTON
  - FINISH: SPIGOT BODY: SATIN NICKEL PLATING
  - MAT'L: AERATOR, HOUSING, CARTRIDGE, AND BUTTON: ALLOY 360, FREE MACHINING BRASS PER ASTM B16 OR EQUIV. ALL OTHER COMPONENTS: 303 CRES, COND. A, PER AMS-5640N OR EQUIV.
  - REMOVE ALL BURRS AND SHARP EDGES
- NOTES: UNLESS OTHERWISE SPECIFIED

1.50	-413	SPIGOT	(NON-SELF VENTING)	190045-413
1.50	-411	SPIGOT	(SELF VENTING)	190045-411
1.50	-409	SPIGOT	(SELF VENTING)	190045-409
2.25	-407	SPIGOT	(NON-SELF VENTING)	190045-407
2.25	-405	SPIGOT	(SELF VENTING)	190045-405
1.50	-403	SPIGOT	(NON-SELF VENTING)	190045-403
1.50	-401	OBSOLETE		190045-401

A DIM	PART NO.	DESCRIPTION	MATERIAL	SIZE	APPLICATION	MAKE FROM
PARTS LIST						
UNLESS OTHERWISE SPECIFIED		DRAWN BY	T. CSIK	9-9-91	SKYLOCK INDUSTRIES INCORPORATED MONROVIA CALIFORNIA U. S. A.	
DIMENSIONS ARE IN INCHES		CHECKED	T. CSIK	3/9/99		
TOLERANCES ON		ENGINEER	T. CSIK	3/9/99		
DECIMALS ANGLES DRILLED HOLES		MFG	P. MATSUOKA	3/18/99		
.XX .01		Q. A.	J. VIVIRITO	3/18/99	SPIGOT	
.XXX .010		DO NOT SCALE THIS DRAWING	USED ON			
MATERIAL - FINISH			SIZE	CODE IDENT. NO.	DRAWING NO.	REV.
MANUFACTURED IN ACCORDANCE WITH SKYLOCK IND. INC. QUALITY CONTROL MANUAL QC.001			C	51941	90045	K
			SCALE	1/1	WT. 4.14.92	SHEET 1 OF 1