

PAOLO ASTORI s.r.l.
via Mirabella 9-MAGGIATE SUP.
I 28013-GATTICO (NO)

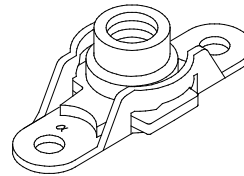

F710
F711

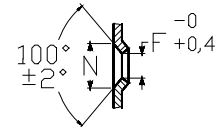
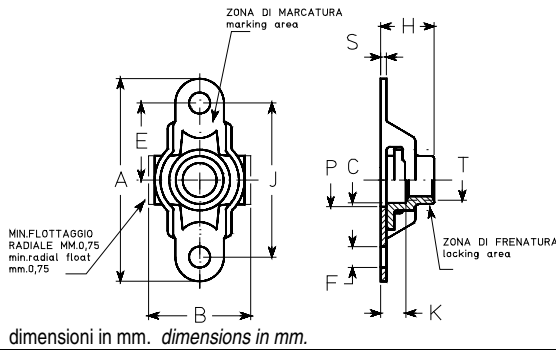

DETTAGLIO DEI FORI DI RIVETTATURA SVASATI
detail of bottom c'sunk rivet holes

codice dimensioni dimensions code	filettatura thread T	tolleranza tolerance	A max.	B max.	C min.	E ±0,1	F 0 +0,2	J ±0,05	H max.	K min.	N ±0,2	P	S max.	massa (kg x 1000) mass (kg x 1000)
03	M3 x 0,5	4H-6H	23,2	10,6	3,4	8,5	2,5	17,00	4,8	1,6	4,8	6,5	0,7	1,5
04	M4 x 0,7	4H-6H	23,2	10,6	4,4	8,5	2,5	17,00	5,8	2,2	4,8	6,5	0,7	1,7
05	M5 x 0,8	4H-6H	25,2	11,0	5,5	9,5	2,5	19,00	6,9	2,4	4,8	6,5	0,7	1,9
06	M6 x 1	4H-5H	29,2	13,1	6,5	11,0	3,3	22,00	8,1	2,7	6,0	7,5	0,7	3,3
08	M8 x 1,25	4H-5H	33,2	15,5	8,5	13,0	3,3	26,00	9,9	3,0	6,0	9,5	0,85	6,3
08F	M8 x 1													
10	M10X1,5	4H-5H	41	17,3	10,6	16	3,3	32	11,5	3,2	6	11,5	1,0	9,5
10F	M10X1,25													

cod. materiali material code	materiale material	finitura finish	durezza HRC hardness HRC	classe resistenza strenght class	classe temperatura temperature class
F710L	W1.7214.4 acciaio-steel/ 25CrMo4	cadmiatura+MoS ₂ cadmium plating+MoS ₂	43 max.	1100 MPa	235°C
F710C		cadmiatura cadmium plating			235°C
F711X	passivazione passivation	27 min.	425°C		
F711L	passivazione+MoS ₂ + puntino verde passivation+MoS ₂ + green dot		315°C		
F711A	argentatura silver plating		425°C		

FILETTO: profilo ISO68; diametro interno per profilo MJ ISO5855.
 MARCATURA: simbolo α del costruttore.
 NORMA di costruzione e controllo: LN65016.
 CADMIATURA: per specifica Astori 8CADTP2000001
 LUBRIFICAZIONE: per AS5272
 DESIGNAZIONE ASTORI: codice materiali-codice dimensioni.
 Esempio: F710C-05 indica una olivetta a disegno F710, in acciaio cadmiato, filettatura M5
 VARIAZIONI: aggiungere una K al codice dimensioni per le olivette con i fori di rivettatura svasati.

THREAD: profile ISO 68; minor diameter according to MJ profile ISO 5855.
 MARKING: manufacturer symbol α.
 PROCUREMENTS specification: LN65016.
 CADMIUM PLATING according to Astori spec. 8CADTP2000001
 LUBRICATION : AS5272
 ASTORI CALL OUT: materials code-dimensions code.
 Example: F710C-5 designates a plate nut according to F710 drawing, in steel, cadmium plated, with M5 thread.
 VARIATIONS: add a K to dimensions code for plate nuts with countersunk rivet holes.

Riferimenti L22575 LN29985	Reference spec LN65007 LN65126	OLIVETTA AUTOFRENANTE FLOTTANTE, ALETTA DOPPIA PLATE NUT, SELF-LOCKING FLOATING, TWO LUGS	F710 F711
----------------------------------	--------------------------------------	--	----------------------