

THE INFORMATION AND DESIGN HEREIN WAS ORIGINATED BY AND IS THE PROPERTY OF SKYLOCK INDUSTRIES INCORPORATED. SKYLOCK INDUSTRIES INCORPORATED RESERVES ALL PATENT, PROPRIETARY, DESIGN MANUFACTURING, REPRODUCTION, USE AND SALES RIGHTS THERE TO, AND TO ANY ARTICLE DISCLOSED THEREIN EXCEPT TO THE EXTENT RIGHTS ARE EXPRESSLY GRANTED TO OTHERS. THE FOREGOING DOES NOT APPLY TO VENDOR PROPRIETARY PARTS.

REVISIONS				
ZONE	LTR	DESCRIPTION	DATE	APPROVED
	NC	PRODUCTION RELEASE	9-10-92	T. CSIK

- NOTES: UNLESS OTHERWISE SPECIFIED.
1. REMOVE ALL BURRS AND BREAK SHARP EDGES.
  2. MAT'L: ALL COMP'S: 300 SERIES CRES.
  3. FINISH: PASSIVATE.
  4. DECORATIVE FINISH: SATIN BUFF TOP OF CASE AND HANDLE.
  5. STATIC LOAD: 600 LBS. MAX.
  6. BOLT IS SPRING LOADED AND ALWAYS FREE TO LATCH.
  7. HANDLE IS SPRING LOADED OPEN WHEN BOLT IS NOT PROPERLY ENGAGED.

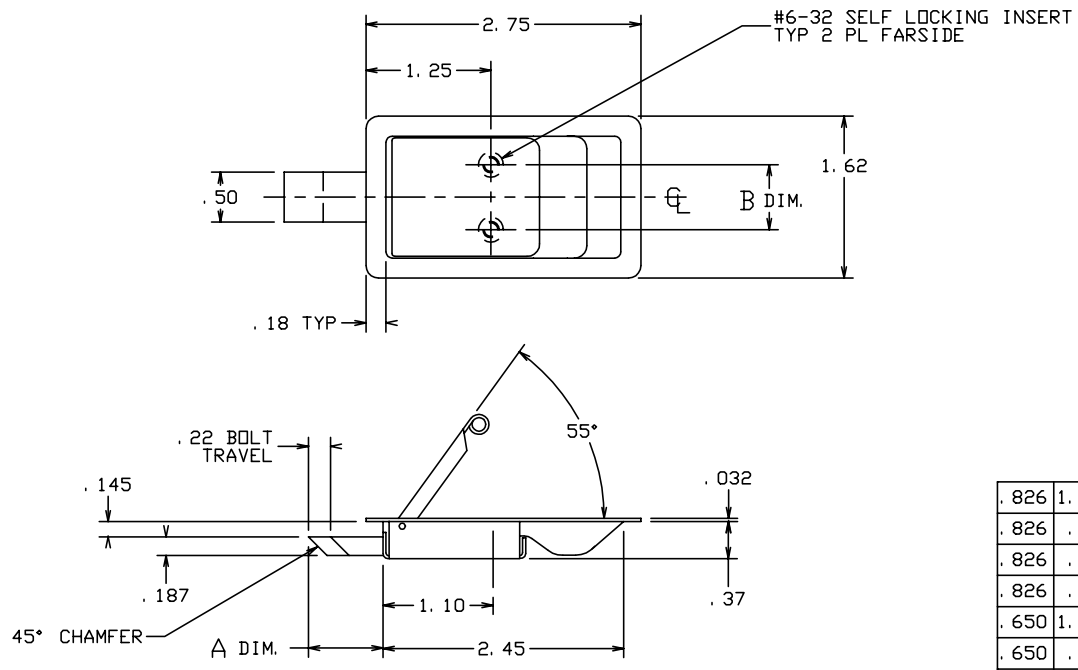

.826	1.30	-15	LATCH ASSY			
.826	.79	-13	LATCH ASSY			
.826	.59	-11	LATCH ASSY			
.826	.37	-9	LATCH ASSY			
.650	1.30	-7	LATCH ASSY			
.650	.79	-5	LATCH ASSY			
.650	.59	-3	LATCH ASSY			
.650	.37	-1	LATCH ASSY			
B DIM	A DIM	PART NO.	DESCRIPTION	MATERIAL	SIZE SPECIFICATION	ITEM NO.

PARTS LIST

UNLESS OTHERWISE SPECIFIED	DRAWN BY T. CSIK	9-10-92	 SKYLOCK INDUSTRIES INCORPORATED MONROVIA CALIFORNIA U. S. A.		
DIMENSIONS ARE IN INCHES	CHECKED				
TOLERANCES ON	ENGINEER				
DECIMALS ANGLES DRILLED HOLES	PROJECT				
.X ± .1 ± 0° 30' AND 10387	APPROVAL T. CSIK	9-10-92	LATCH ASSEMBLY		
.XX ± .03	APPROVAL				
.XXX ± .010					
DO NOT SCALE THIS DRAWING	USED ON				
MATERIAL - FINISH	USED ON	SIZE	CODE IDENT. NO.	DRAWING NO.	REV.
NEXT ASSY		C	51941	20790	NC
FINAL ASSY		SCALE	1: 1	VT.	SHEET 1 OF 1