

THE INFORMATION AND DESIGN HEREIN WAS ORIGINATED BY AND IS THE PROPERTY OF SKYLOCK INDUSTRIES INCORPORATED. SKYLOCK INDUSTRIES INCORPORATED RESERVES ALL PATENT, PROPRIETARY, DESIGN MANUFACTURING, REPRODUCTION, USE AND SALES RIGHTS THEREIN, AND TO ANY ARTICLE DISCLOSED THEREIN EXCEPT TO THE EXTENT RIGHTS ARE EXPRESSLY GRANTED TO OTHERS. THE FOREGOING DOES NOT APPLY TO VENDOR PROPRIETARY PARTS.

REVISIONS				
ZONE	LTR	DESCRIPTION	DATE	APPROVED
	NC	PRODUCTION RELEASE	4.29.92	SC
	A	ADDED -2	7-9-93	TC
	B	ADDED -3	2-5-98	TC

NOTES: UNLESS OTHERWISE SPECIFIED

1. REMOVE ALL BURRS AND SHARP EDGES
2. MAT'L: HOUSING, BOLT, BACKPLATE, AND ESCUTCHEONS; ALUM ALLOY; ALL OTHER COMPONENTS; CRES
3. FINISH: ALUM; CLEAR ANODIZE; CRES; PASSIVATE
4. DECORATIVE FINISH: SATIN BRUSH AND CLEAR ANODIZE
5. BOLT IS SPRING LOADED OUTWARD- RED DOT VISIBLE IF BOLT IS NOT FULLY EXTENDED

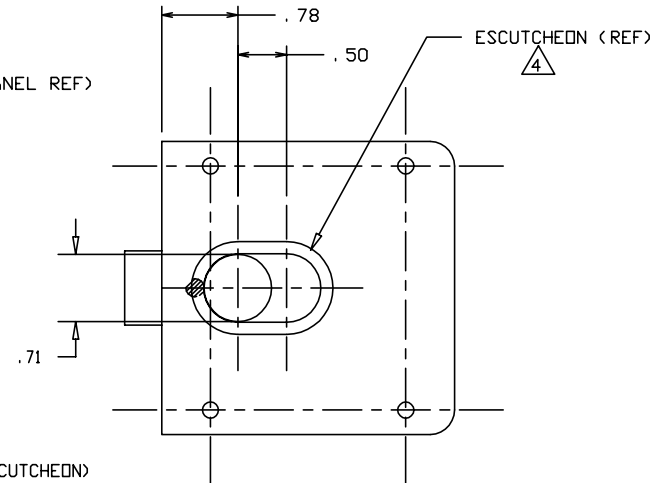
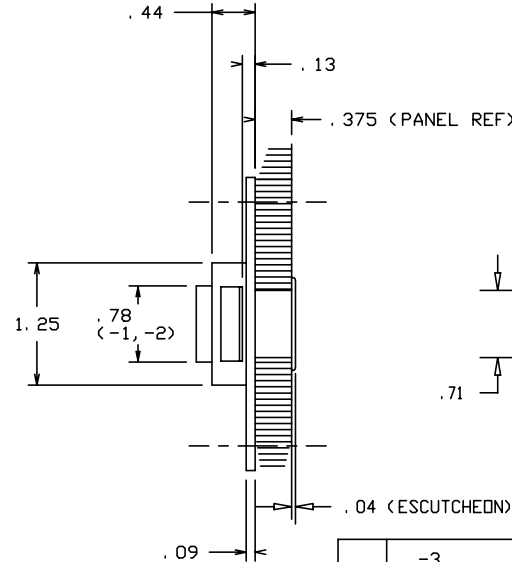
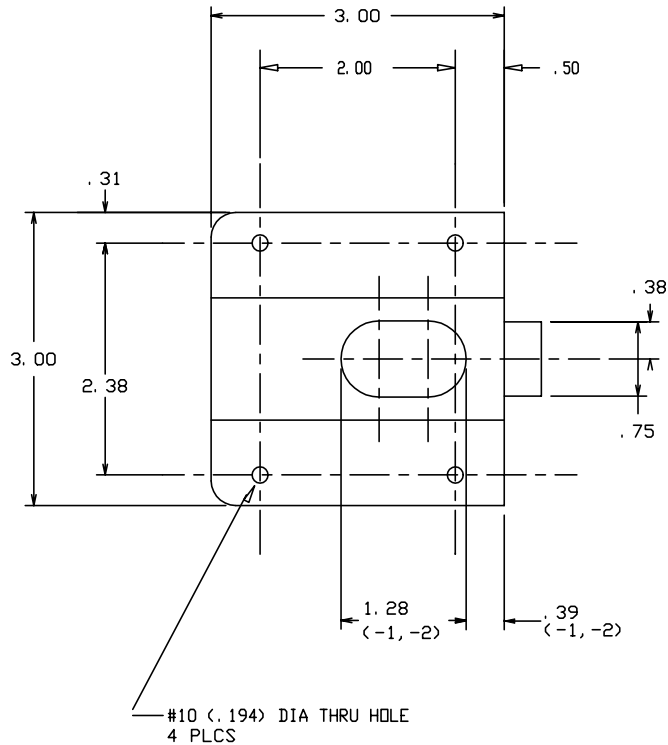
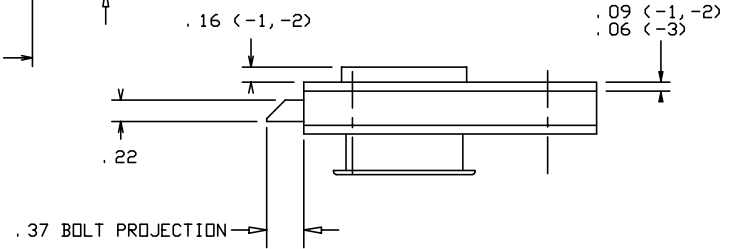
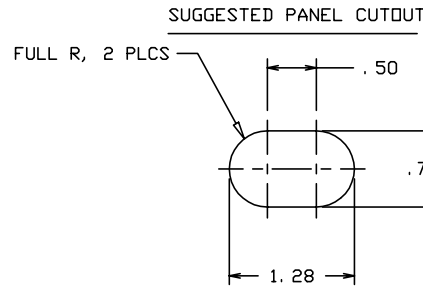

	-3	LATCH ASSY	(BOLT BEVEL AS SHOWN)	
	-2	LATCH ASSY	(REVERSED BOLT BEVEL)	
	-1	LATCH ASSY	(BOLT BEVEL AS SHOWN)	
QTY. REV'D	PART / IDENT NO.	DESCRIPTION	MATERIAL / SPECIFICATION	ITEM NO.
UNLESS OTHERWISE SPECIFIED DIMENSIONS ARE IN INCHES		CONTRACT NO.		SKYLOCK INDUSTRIES INCORPORATED MONROVIA, CALIFORNIA, USA
TOLERANCES DECIMALS .XX .03 .XXX .010		CUSTOMER		
ANGULAR 0 30'		DRAWN BY S. CSIK		LATCH ASSY- DEADBOLT
DO NOT SCALE DRAWING		DATE		
NEXT ASSY	FINAL ASSY	DESIGN	CHECK	REV. B
USED DN	DESIGN ACTIVITY		SIZE C	FSCM NO. 51941
FINISH	ACT WT	CALC WT	SCALE 1/1	DRAWING NO. 20760
			RELEASE DATE 4.22.92	SHEET 1 OF 1