

THE INFORMATION AND DESIGN HEREIN WAS ORIGINATED BY AND IS THE PROPERTY OF SKYLOCK INDUSTRIES INCORPORATED. SKYLOCK INDUSTRIES INCORPORATED RESERVES ALL PATENT, PROPRIETARY, DESIGN MANUFACTURING, REPRODUCTION, USE AND SALES RIGHTS THERE TO, AND TO ANY ARTICLE DISCLOSED THEREIN EXCEPT TO THE EXTENT RIGHTS ARE EXPRESSLY GRANTED TO OTHERS. THE FOREGOING DOES NOT APPLY TO VENDOR PROPRIETARY PARTS.

REVISIONS				
ZONE	LTR	DESCRIPTION	DATE	APPROVED
	NC	PRODUCTION RELEASE	8/23/99	T. CSIK

- NOTES: UNLESS OTHERWISE SPECIFIED.
- REMOVE ALL BURRS AND BREAK SHARP EDGES.
 - MAT'L REF.: HANDLE, ESCUTCHEON & LATCH; 2024-T3/T35 ALUM, PER ASTM B-209, OR EQUIV. SPINDLE, HOOK & STRIKE; 300 SERIES CRES, PER AMS-5640N OR EQUIV.
 - FINISH REF.: ALUM. CLEAR ANODIZE PER MIL-A-8625, TYPE II, CLASS 1. CRES; PASSIVATE PER AMS-QQ-P-35, TYPE II OR EQUIV. ALLOY STL.; CAD PLATE PER QQ-P-416, TYPE II, CLASS 2.
 - TURN HANDLE CLOCKWISE TO EXTEND & LOCK HOOK, TURN HANDLE COUNTERCLOCKWISE TO RETRACT & UNLOCK HOOK.
 - DECORATIVE FINISH REF.: ESCUTCHEON & HANDLE; SATIN BRUSH AS SHOWN.
 - HEAT TREAT BOLT TO 45-50 K. S. I.
 - APPLICABLE TO FAA-PMA REPLACEMENT OR MODIFICATION PARTS ONLY. PER FAR 45.15, PARTS WILL BE IDENTIFIED WITH:
 - FAA-PMA.
 - SKYLOCK IND. INC.
 - PART NO.
 - AIRCRAFT INSTALLATION ELIGIBILITY.

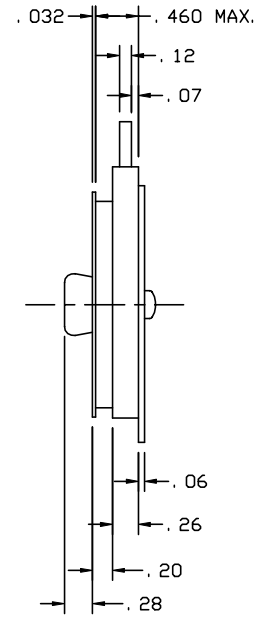
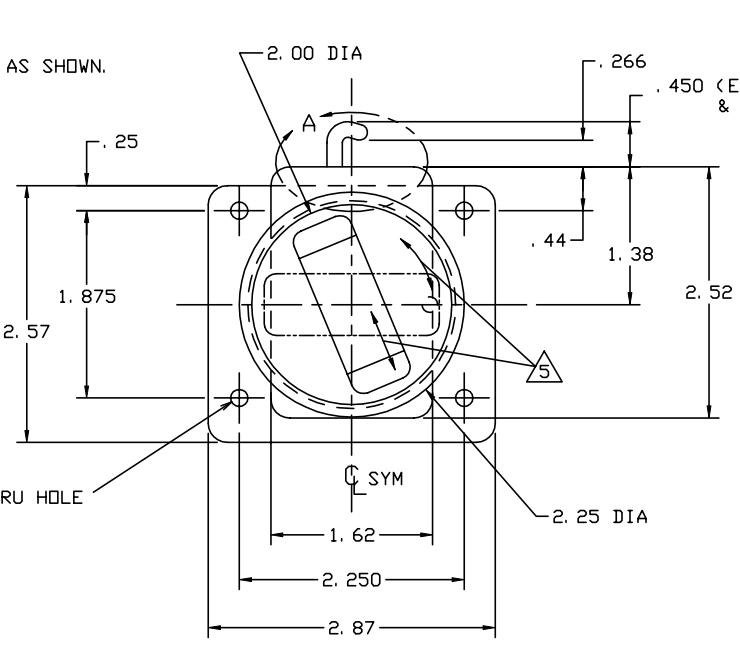
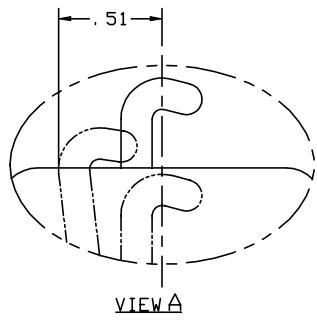

-3 HOOK LATCH

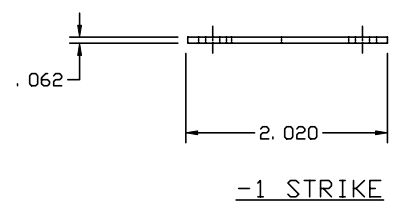
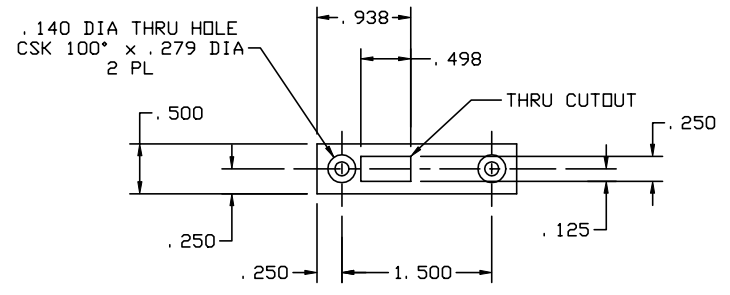

QTY	PART NO.	DESCRIPTION	MAKE FROM
1	-5	HOOK LATCH	120967-5
1	-3	HOOK LATCH	120967-3
1	-1	STRIKE	646-7
-403	-401	PART NO.	DESCRIPTION
			MAKE FROM

PARTS LIST

UNLESS OTHERWISE SPECIFIED	DRAWN BY	ED WELSH	4/21/99	SKYLOCK INDUSTRIES INCORPORATED MONROVIA CALIFORNIA U. S. A.
DIMENSIONS ARE IN INCHES	CHECKED	T. CSIK	8/23/99	
TOLERANCES ON	ENGINEER	T. CSIK	8/23/99	
DECIMALS ANGLES DRILLED HOLES	QC	J. VIVIRITO	8/23/99	
.X ± .1 ± 0° 30' AND 10387	WFG	P. MATSUOKA	8/23/99	
.XXX ± .010				
DO NOT SCALE THIS DRAWING				
MATERIAL - FINISH	USED ON	SIZE	CODE IDENT. NO.	DRAWING NO.
		C		20967
NEXT ASSY		SCALE	1:1	REV. NC
MANUFACTURE IN ACCORDANCE WITH SKYLOCK IND. INC., QUALITY CONTROL MANUAL QC.001		SCALE	1:1	SHEET 1 OF 2

THE INFORMATION AND DESIGN HEREIN WAS ORIGINATED BY AND IS THE PROPERTY OF SKYLOCK INDUSTRIES INCORPORATED. SKYLOCK INDUSTRIES INCORPORATED RESERVES ALL PATENT, PROPRIETARY, DESIGN MANUFACTURING, REPRODUCTION, USE AND SALES RIGHTS THERE TO, AND TO ANY ARTICLE DISCLOSED THEREIN EXCEPT TO THE EXTENT RIGHTS ARE EXPRESSLY GRANTED TO OTHERS. THE FOREGOING DOES NOT APPLY TO VENDOR PROPRIETARY PARTS.

REVISIONS				
ZONE	LTR	DESCRIPTION	DATE	APPROVED
	NC	PRODUCTION RELEASE		

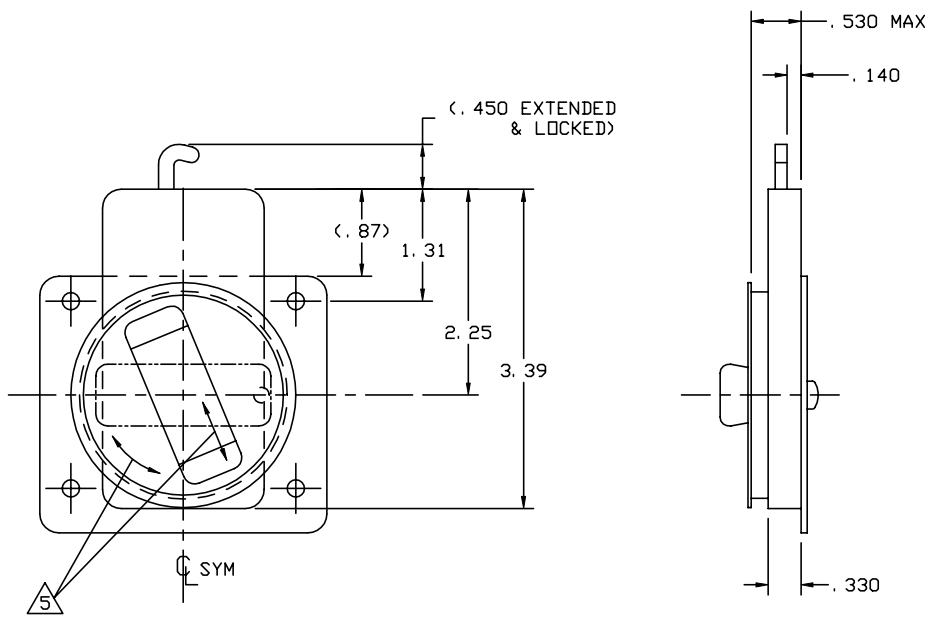

-5 HOOK LATCH
(S/A -3 EXCEPT AS SHOWN)

 SKYLOCK INDUSTRIES INCORPORATED
 MONROVIA CALIFORNIA U. S. A.

HOOK LATCH

SIZE C	CODE IDENT. NO.	DRAWING NO. 20967	REV. NC
SCALE 1: 1	VT.	SHEET 2	OF 2