

PAOLO ASTORI

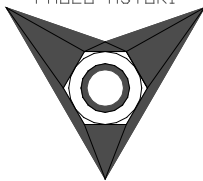

PAOLO ASTORI s.r.l.
via Mirabella 9-MAGGIATE SUP.
I 28013-GATTICO (NO)

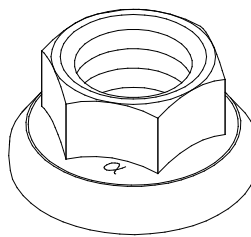

DRS10
DRS11

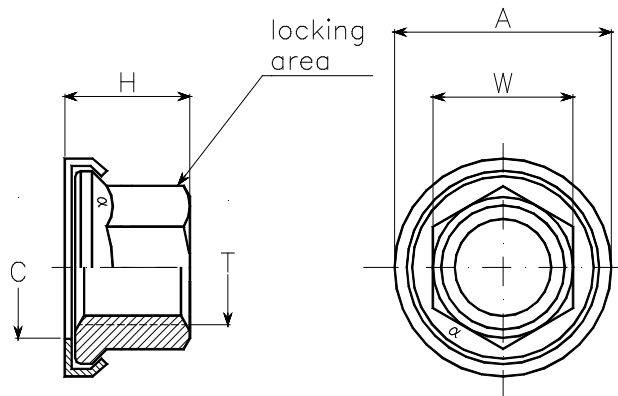

dimensioni in mm. dimensions in mm.

codice dimensioni dimensions code	filettatura T thread T	A max.	C min.	H max.	W h13	mass kg x 1000
03	M3x0,5 4H-6H	7,0	3,2	3,5	4	0,44
04	M4x0,7 4H-6H	9,0	4,3	4,6	5	0,95
05	M5x0,8 4H-6H	10,8	5,3	5,5	6	1,32
06	M6x1 4H-5H	12,0	6,5	6,2	7	1,80
07	M7x1 4H-5H	13,6	7,5	6,7	8	2,70
08F	M8x1 4H-5H	15,0	8,5	7,5	10	3,85
08	M8x1,25 4H-5H	15,0	8,5	7,5	10	3,85
10F	M10x1,25 4H-5H	17,4	10,6	9,0	12	6,0
10	M10x1,5 4H-5H	17,4	11,6	9,0	12	6,0
12	M12x1,5 4H-5H	20,9	12,6	11,4	14	9,5

material code	material		finish		hardnes s HR _C	strenght class	temperature class
	washer	nut	washer	nut			
DRS10L	W1.7214.4 steel	W1.7220.4 steel	cadmiatura	cadmiatura +MoS ₂	44 max.	1100 MPa	235°C
DRS10C	25CD4	35CrMo4		cadmiatura			
DRS11X			passivazione				
DRS11L	W1.4544.9 AISI321	W1.4944.4 alloy A286	passivazione	passivazione+Mo s + green dot	28-36	425°C	
DRS11A				argentatura		650°C	

THREAD: according to ISO 5855.
MARKING: Manufacturer identification symbol α
PROCUREMENT SPEC.: LN65016
ASTORI CALL-OUT: material code - dimensions code.

CADMIUM PLATING: QQ-P-416
SILVER PLATING: AMS2410
PASSIVATION: QQ-P-35
LUBRICATION: MIL-L-46010

**DADO AUTOFRENANTE, ESAGONO RIDOTTO, RONDELLA INCORPORATA.
NUT, SELF-LOCKING, REDUCED HEX, CAPTIVE WASHER**

DRS10
DRS11