

PAOLO ASTORI s.r.l.  
via Mirabella 9-MAGGIATE SUP.  
I 28013-GATTICO (NO)

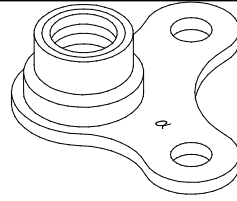

**O350**  
**O351**

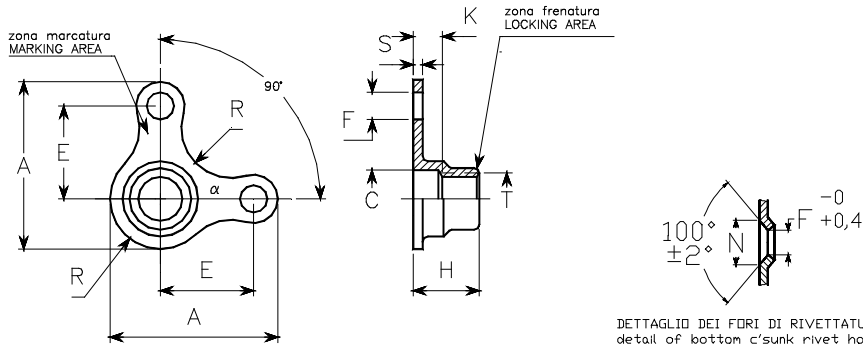

dimensioni in mm. dimensions in mm.

codice dimensioni dimensions code	filettatura thread T	tolleranza tolerance	A max.	C ±0,05	E ±0,1	F 0 +0,2	H max.	K min.	N ±0,25	R max.	S max.	massa (kg x 1000) mass (kg x 1000)
04	M4 x 0,7	4H-6H	12,7	4,2	6,0	2,5	5,2	1,6	4,8	4,0	0,9	1,0
05	M5 x 0,8	4H-6H	14,2	5,2	7,0	2,5	6,2		4,8	4,5	1,0	1,3
06	M6 x 1	4H-5H	16,2	6,2	8,0	2,5	7,1		5,8	5,0	1,2	1,8

cod. materiali material code	materiale material	finitura finish	durezza HR <sub>C</sub> hardness HR <sub>C</sub>	classe resistenza strenght class	classe temperatura temperature class
O350L	W1.7214.4 acciaio-steel	cadmiatura+MoS <sub>2</sub> cadmium plating+MoS <sub>2</sub>	43 max.	900 MPa	235°C
O350C	25CrMo4	cadmiatura cadmium plating			235°C
O351X	W1.4944.4 lega A286 A286 alloy	passivazione passivation	27 min.		425°C
O351L		passivazione+MoS <sub>2</sub> + puntino verde passivation+MoS <sub>2</sub> + green dot			315°C
O351A		argentatura silver plating			425°C

FILETTO: profilo ISO 68; diam. foro filetto per filett. MJ ISO5855.  
MARCATURA: simbolo α del costruttore.  
NORMA di costruzione e controllo: LN65016.  
DESIGNAZIONE ASTORI: codice materiali-codice dimensioni.  
Esempio: O350C-05 indica una olivetta a disegno O350, in acciaio cadmiato, filettatura M5  
VARIAZIONI: aggiungere una K al codice dimensioni per le olivette con i fori di rivettatura svasati.

THREAD: profile ISO68; minor diam. according to MJ profile ISO 5855.  
MARKING: manufacturer symbol α  
PROCUREMENTS specification: LN65016.  
ASTORI CALL OUT: materials code-dimensions code.  
Example: O350C-5 designates a plate nut according to O350 drawing, in steel, cadmium plated, with M5 thread.  
VARIATIONS: add a K to dimensions code for plate nuts with countersunk rivet holes.

Reference	<b>OLIVETTA AUTOFRENANTE, MINIATURA AD ANGOLO 90°, FISSA ANCHOR NUT, SELF-LOCKING, MINIATURE CORNER 90°, FIXED</b>	<b>O350</b> <b>O351</b>
-----------	--	----------------------------