

THE INFORMATION AND DESIGN HEREIN WAS ORIGINATED BY AND IS THE PROPERTY OF SKYLOCK INDUSTRIES INCORPORATED. SKYLOCK INDUSTRIES INCORPORATED RESERVES ALL PATENT, PROPRIETARY, DESIGN MANUFACTURING, REPRODUCTION, USE AND SALES RIGHTS THERE TO, AND TO ANY ARTICLE DISCLOSED THEREIN EXCEPT TO THE EXTENT RIGHTS ARE EXPRESSLY GRANTED TO OTHERS. THE FOREGOING DOES NOT APPLY TO VENDOR PROPRIETARY PARTS.

REVISIONS				
ZONE	LTR	DESCRIPTION	DATE	APPROVED
	NC	PRODUCTION RELEASE	1-13-95	T. C.

NOTES: UNLESS OTHERWISE SPECIFIED.

- MAT'L: HANDLE; 6061-T6 ALUM. ALLOY, BOLT; PLASTIC, POLYCARBONATE, ALL OTHER COMPS; CRES.
- FINISH: CRES.; PASSIVATE PER QQ-P-35, OR GLASS BEAD PEEN.
- DECORATIVE FINISH: SATIN BUFF.
- STATIC LOAD 200 LBS.
- BOLT IS DETENTED IN THE EXTENDED AND RETRACTED POSITION.

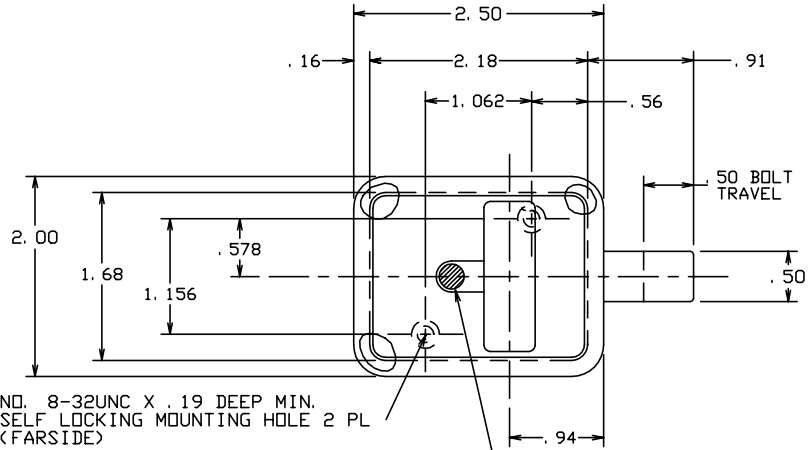

NO. 8-32UNC X .19 DEEP MIN. SELF LOCKING MOUNTING HOLE 2 PL (FAR SIDE)

GREEN DOT IS SHOWN WHEN BOLT IS EXTENDED
RED DOT IS SHOWN WHEN BOLT IS RETRACTED

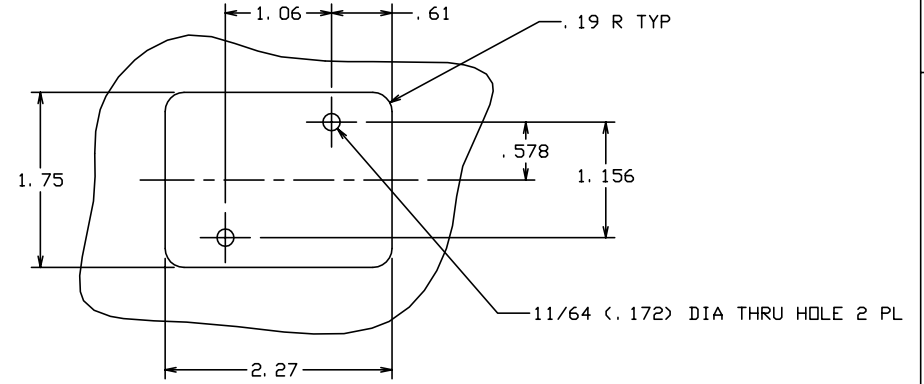

DOOR CUTOUT INFORMATION

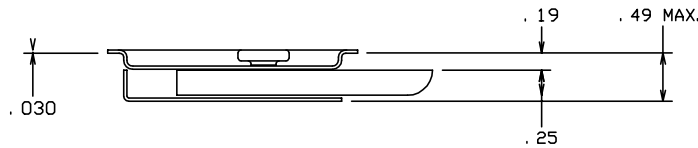

-1 LATCH					
PART NO.	DESCRIPTION	MATERIAL	SIZE	SPECIFICATION	ITEM NO.
PARTS LIST					
UNLESS OTHERWISE SPECIFIED		DRAWN BY T. CSIK		1-13-95	
DIMENSIONS ARE IN INCHES		CHECKED		SKYLOCK INDUSTRIES INCORPORATED MONROVIA CALIFORNIA U. S. A.	
TOLERANCES ON		ENGINEER			
DECIMALS ANGLES DRILLED HOLES		PROJECT			
.X ± .1 ± 0° 30' AND 10387		APPROVAL T. CSIK		1-13-95	
.XX ± .03		APPROVAL			
.XXX ± .010					
DO NOT SCALE THIS DRAWING					
MATERIAL - FINISH		USED ON		SIZE	CODE IDENT. NO. DRAWING NO.
NEXT ASSY				C	51941 20909
FINAL ASSY				SCALE	1:1
				WT.	SHEET 1 OF 1

LATCH ASSY