

THE INFORMATION AND DESIGN HEREIN WAS ORIGINATED BY AND IS THE PROPERTY OF SKYLOCK INDUSTRIES INCORPORATED. SKYLOCK INDUSTRIES INCORPORATED RESERVES ALL PATENT, PROPRIETARY, DESIGN MANUFACTURING, REPRODUCTION, USE AND SALES RIGHTS THERE TO, AND TO ANY ARTICLE DISCLOSED THEREIN EXCEPT TO THE EXTENT RIGHTS ARE EXPRESSLY GRANTED TO OTHERS. THE FOREGOING DOES NOT APPLY TO VENDOR PROPRIETARY PARTS.

REVISIONS				
ZONE	LTR	DESCRIPTION	DATE	APPROVED
	NC	PRODUCTION RELEASE	3-31-92	T. CSIK

NOTES: UNLESS OTHERWISE SPECIFIED.

1. REMOVE ALL BURRS AND BREAK SHARP EDGES.
2. MAT'L: CASE AND LEVER; ALUM. ALLOY, LOCK ASSY; ZINC, ALL OTHERS COMP'S; STL.
3. FINISH: SATIN BUFF AND CLEAR ANODIZE CASE AND LEVER,
4. LEVER IS DETENTED IN LOCKED AND UNLOCKED POSITIONS,
5. KEYING: FOUR DISC TUMBLER, KEYED ALIKE. KEYED DIFFERENT OR SPECIAL KEYING AVAILABLE ON SPECIAL ORDER. KEY IS REMOVABLE IN LOCKED AND UNLOCKED POSITIONS.

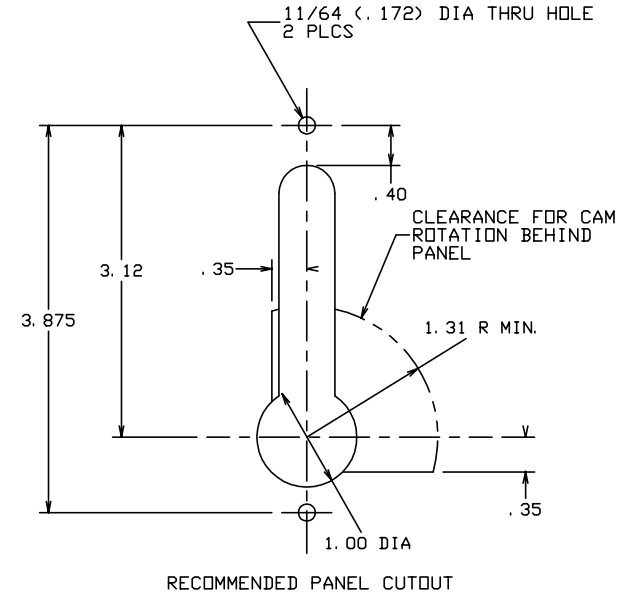
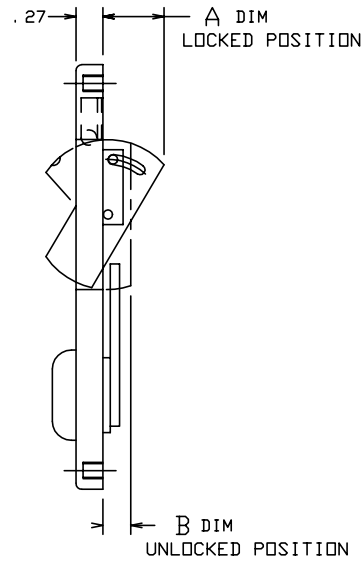
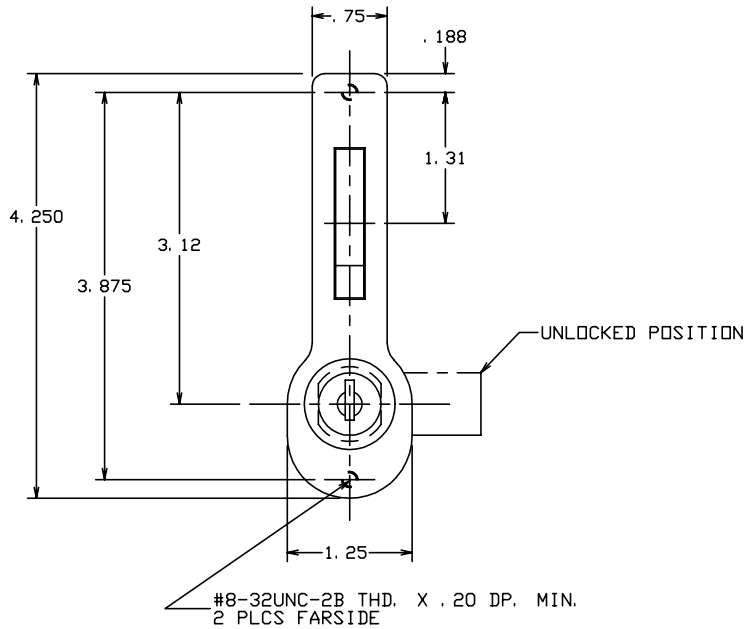
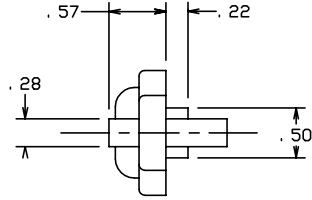

B DIM	A DIM	PART NO.	DESCRIPTION	MATERIAL	SIZE	SPECIFICATION	ITEM NO.
.28	.61	-3	SECURITY LATCH				
.30	.65	-1	SECURITY LATCH				

PARTS LIST		DRAWN BY		DATE		MATERIAL		SIZE		CODE IDENT. NO.		DRAWING NO.		REV.	
UNLESS OTHERWISE SPECIFIED		T. CSIK		3-31-92		SKYLOCK INDUSTRIES INCORPORATED MONROVIA CALIFORNIA U. S. A.		C		51941		20412		NC	
DIMENSIONS ARE IN INCHES		CHECKED													
TOLERANCES ON		ENGINEER													
DECIMALS		PROJECT													
ANGLES		APPROVAL		T. CSIK		3-31-92									
DRILLED HOLES		APPROVAL													
.X ± .1															
.XX ± .03															
.XXX ± .010															
DO NOT SCALE THIS DRAWING															
MATERIAL - FINISH		USED ON													
NEXT ASSY															
FINAL ASSY															
								SCALE		1: 1		SHEET		1 OF 1	

SECURITY LATCH-
SLIDING DOOR