

THE INFORMATION AND DESIGN HEREIN WAS ORIGINATED BY AND IS THE PROPERTY OF SKYLOCK INDUSTRIES INCORPORATED. SKYLOCK INDUSTRIES INCORPORATED RESERVES ALL PATENT, PROPRIETARY, DESIGN MANUFACTURING, REPRODUCTION, USE AND SALES RIGHTS THERE TO, AND TO ANY ARTICLE DISCLOSED THEREIN EXCEPT TO THE EXTENT RIGHTS ARE EXPRESSLY GRANTED TO OTHERS. THE FOREGOING DOES NOT APPLY TO VENDOR PROPRIETARY PARTS.

REVISIONS				
ZONE	LTR	DESCRIPTION	DATE	APPROVED
	D	-3 REMOVED .25 DIA THRU HOLE, ADDED RED AND GREEN INDICATOR SLOTS	7-9-96	T. CSIK

- NOTES: UNLESS OTHERWISE SPECIFIED.
1. REMOVE ALL BURRS AND BREAK SHARP EDGES.
  2. MAT'L: CASE AND LEVER; ALUM. ALLOY, ALL OTHERS COMP' S; ST. STL.
  3. FINISH: SATIN BUFF AND CLEAR ANODIZE CASE AND LEVER,
  4. TRIGGER IS DETENTED IN THE LATCHED AND UNLATCHED POSITIONS.

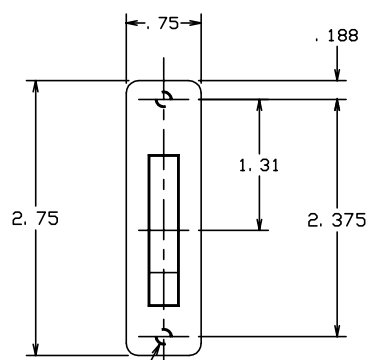
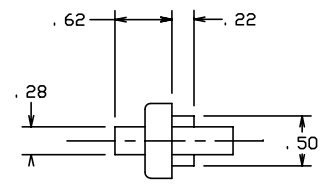

8-32UNC-2B THD. HOLE X .20 DP.  
TYP 2 PL FAR SIDE

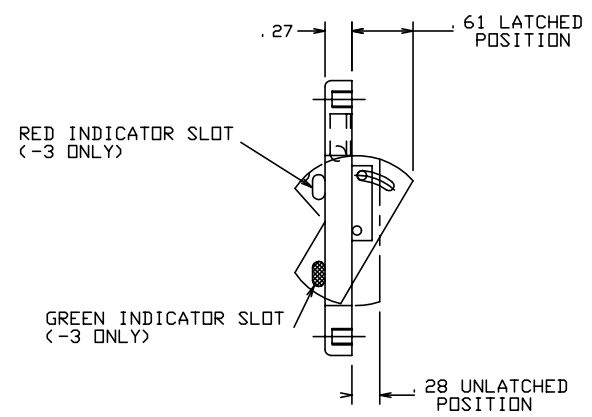

	-3	LATCH, SLIDING DOOR			
	-1	LATCH, SLIDING DOOR			
PART NO.	DESCRIPTION	MATERIAL	SIZE	SPECIFICATION	ITEM NO.
PARTS LIST					
UNLESS OTHERWISE SPECIFIED		DRAWN BY T. S.	1-8-88	 SKYLOCK INDUSTRIES INCORPORATED MONROVIA CALIFORNIA U. S. A.	
DIMENSIONS ARE IN INCHES		CHECKED			
TOLERANCES ON		ENGINEER			
DECIMALS ANGLES DRILLED HOLES		PROJECT			
.X ± .1 ± 0° 30' AND 10367		APPROVAL D. SHORT	1-8-88	LATCH- SLIDING DOOR	
.XXX ± .010		APPROVAL			
DO NOT SCALE THIS DRAWING		APPROVAL			
MATERIAL - FINISH	USED ON	SIZE	CODE IDENT. NO.	DRAWING NO.	REV.
NEXT ASSY		C	51941	20613	D
FINAL ASSY		SCALE	1: 1	VT.	SHEET 1 OF 1