

THE INFORMATION AND DESIGN HEREIN WAS ORIGINATED BY AND IS THE PROPERTY OF SKYLOCK INDUSTRIES INCORPORATED. SKYLOCK INDUSTRIES INCORPORATED RESERVES ALL PATENT, PROPRIETARY, DESIGN MANUFACTURING, REPRODUCTION, USE AND SALES RIGHTS THERE TO, AND TO ANY ARTICLE DISCLOSED THEREIN EXCEPT TO THE EXTENT RIGHTS ARE EXPRESSLY GRANTED TO OTHERS. THE FOREGOING DOES NOT APPLY TO VENDOR PROPRIETARY PARTS.

REVISIONS:				
ZONE	LTR	DESCRIPTION	DATE	APPROVED
NC		PRODUCTION RELEASE	10/90	SC
A		REDRAWN AND REVISED	2-8-91	JL
B		REDRAWN AND REVISED	3-22-91	JL
C		INSERTS WERE 6-32 (5 PLCS)	5.1.91	SC
D		ROLLERS WERE .62 DIA-2 PLCS	5.21.91	TC
E		ADDED -405 AND -406	4.17.2	SC

NOTES: UNLESS OTHERWISE SPECIFIED

1. REMOVE ALL BURRS AND SHARP EDGES
2. MAT'L: ROLLER BLOCK CHASSIS; 6061-T6 ALUM ALLOY; ROLLERS; BLACK NYLON 6/6; ALL OTHER PARTS; CRES
3. FINISH: ALUM; CLEAR ANODIZE CRES; PASSIVATE

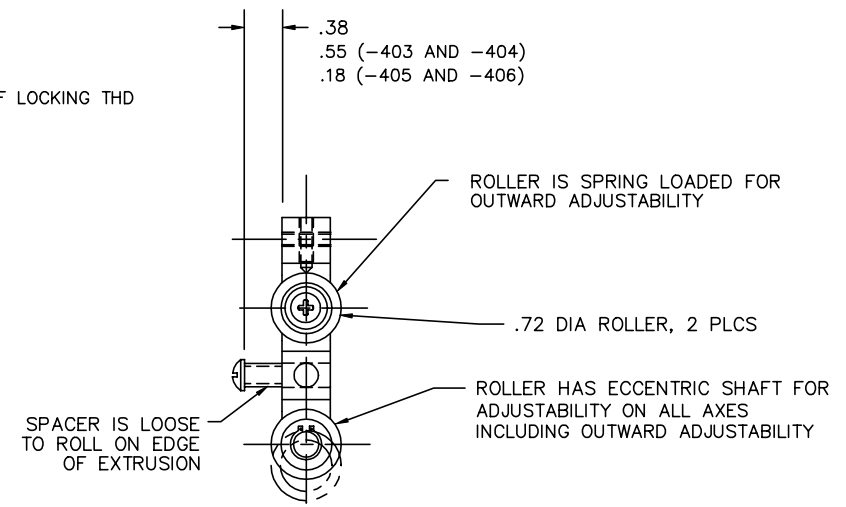
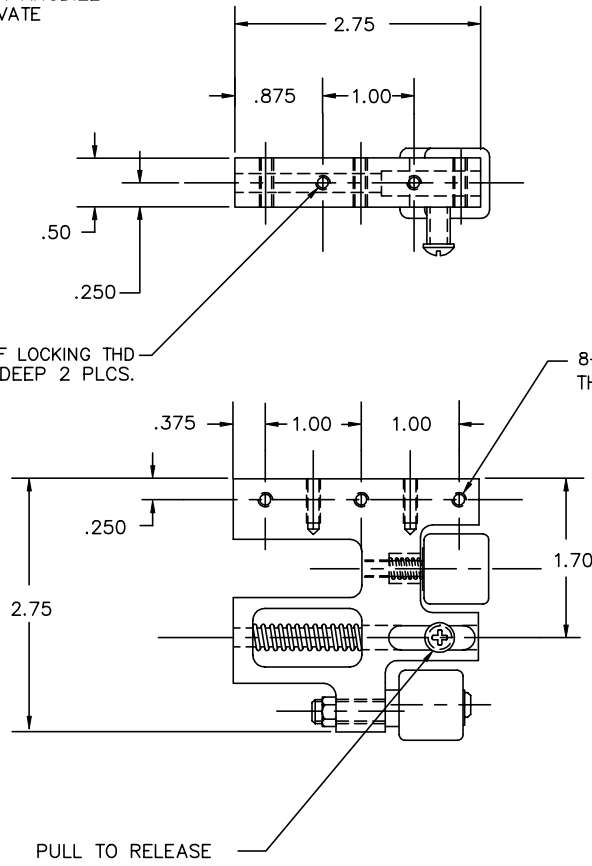

	-406	ROLLER BLOCK ASSY	OPPOSITE	
	-405	ROLLER BLOCK ASSY	SHOWN	
	-404	ROLLER BLOCK ASSY	OPPOSITE	
	-403	ROLLER BLOCK ASSY	SHOWN	
	-402	ROLLER BLOCK ASSY	OPPOSITE	
	-401	ROLLER BLOCK ASSY	SHOWN	
QTY REQ'D	PART / IDENT NO.	DESCRIPTION	MATERIAL / SPECIFICATION	ITEM NO.

UNLESS OTHERWISE SPECIFIED: DIMENSIONS ARE IN INCHES		CONTRACT NO.		SKYLOCK INDUSTRIES INCORPORATED MONROVIA, CALIFORNIA, USA	
DECIMALS .XX ± .03 .XXX ± .010 DO NOT SCALE DRAWING	ANGULAR ± 0 30'	DRAWN BY SC	DATE 10/90		
NEXT ASSY FINAL ASSY		CHECK		ROLLER BLOCK ASSY	
USED ON		DESIGN SC	DATE 10/90		
FINISH NOTED		DESIGN ACTIVITY		SIZE C	FSCM NO. 51941
ACT WT		CUSTOMER		DRAWING NO. 20690	REV. E
CALC WT				SCALE NONE	RELEASE DATE 11/1/90
				SHEET 1 OF 1	

DRAWING NO.

SHEET OF REV.