

THE INFORMATION AND DESIGN HEREIN WAS ORIGINATED BY AND IS THE PROPERTY OF SKYLOCK INDUSTRIES INCORPORATED. SKYLOCK INDUSTRIES INCORPORATED RESERVES ALL PATENT, PROPRIETARY, DESIGN MANUFACTURING, REPRODUCTION, USE AND SALES RIGHTS THERE TO, AND TO ANY ARTICLE DISCLOSED THEREIN EXCEPT TO THE EXTENT RIGHTS ARE EXPRESSLY GRANTED TO OTHERS. THE FOREGOING DOES NOT APPLY TO VENDOR PROPRIETARY PARTS.

REVISIONS				
ZONE	LTR	DESCRIPTION	DATE	APPROVED
	NC	PRODUCTION RELEASE	8-23-93	T. CSIK
	A	DIM. IS 2.80 WAS 3.25, IS 1.46 WAS 2.00, PUSH BUTTON COLOR IS WHITE WAS WHITE PER BAC746.	9-7-93	T. CSIK
	B	PRESSURE WAS 0-125 P. S. I. G.	4-12-94	T. CSIK

- NOTES: UNLESS OTHERWISE SPECIFIED.
- MAT'L: SPIGOT BODY; BRASS, VALVE ASSY; CRES. PUSH BUTTON; PLASTIC, COLOR - WHITE.
 - DECORATIVE FINISH: BRIGHT CHROME PLATE, EXCEPT BUTTON.

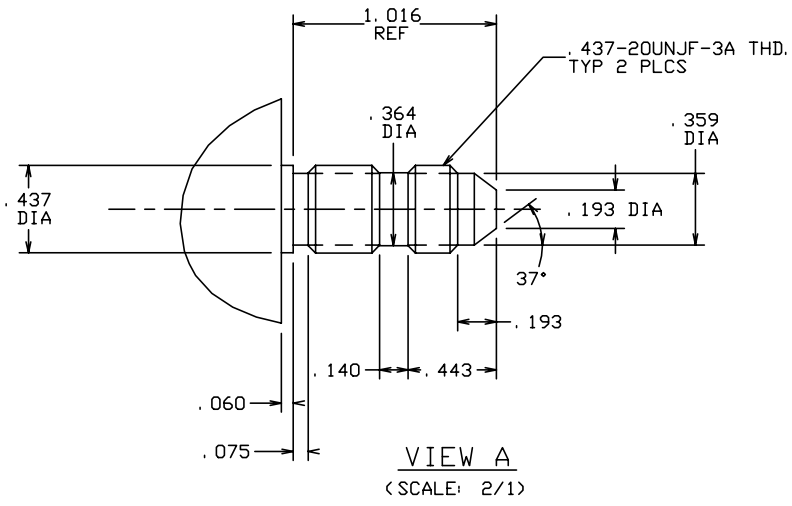
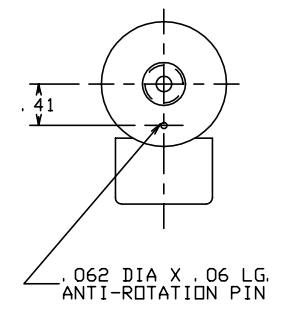
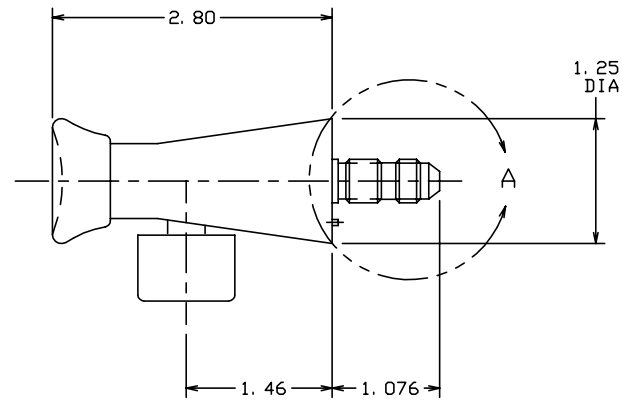
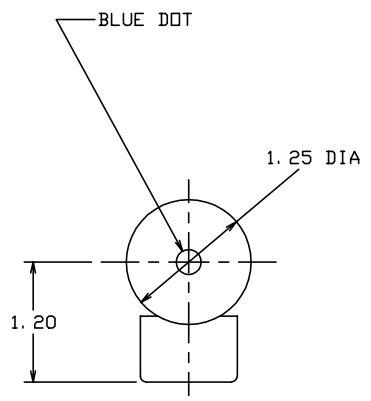

-401		SPIGOT ASSY			
QTY REQD	PART NO.	DESCRIPTION	MATERIAL	SIZE	SPECIFICATION
PARTS LIST					
UNLESS OTHERWISE SPECIFIED		DRAWN BY	T. CSIK	8-23-93	SKYLOCK INDUSTRIES INCORPORATED MONROVIA CALIFORNIA U. S. A.
DIMENSIONS ARE IN INCHES		CHECKED			
TOLERANCES ON		ENGINEER			
DECIMALS ANGLES DRILLED HOLES		PROJECT			
.X ± .1 ± 0° 30' AND 10387		APPROVAL	T. CSIK	8-23-93	SPIGOT ASSY
.XX ± .03					
.XXX ± .010					
DO NOT SCALE THIS DRAWING					
MATERIAL - FINISH		USED ON		SIZE	CODE IDENT. NO. DRAWING NO.
NEXT ASSY				C	51941 90078
FINAL ASSY				SCALE	1/1 & NOTED
				SHEET	1 OF 1

FLUID MEDIA	TYPE	OPERATING PRESSURE	OPERATING TEMP.	FLOW
POTABLE WATER	SELF VENTING & BLEEDING	0-200 PSIG	35°F TO 225°F	100/140 OZ. /MIN. AT 70°F AND 30 P. S. I. INLET PRESSURE