

PAOLO ASTORI s.r.l.
via Mirabella 9-MAGGIATE SUP.
I 28013-GATTICO (NO)

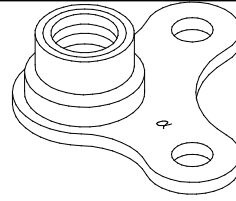

O300
O301

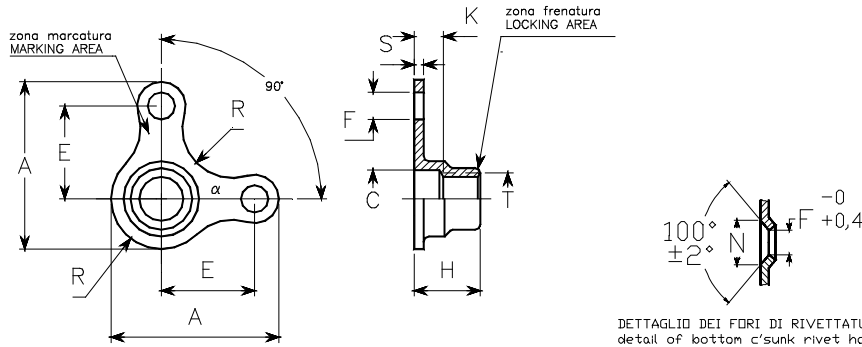

DETTAGLIO DEI FORI DI RIVETTATURA SVASATI
detail of bottom c'sunk rivet holes

dimensioni in mm. dimensions in mm.

codice dimensioni dimensions code	filettatura thread T	tolleranza tolerance	A max.	C ±0,05	E ±0,1	F 0 +0,2	H max.	K min.	N ±0,25	R max.	S max.	massa (kg x 1000) mass (kg x 1000)
03	M3 x 0,5	4H-6H	11,7		6,0	2,5	3,2		4,8	3,0	0,7	0,4
04	M4 x 0,7	4H-6H	15,7	4,2	8,5	2,5	5,2		4,8	4,0	1,0	1,0
05	M5 x 0,8	4H-6H	17,2	5,2	9,5	2,5	6,2		4,8	4,5	1,0	1,3
06	M6 x 1	4H-5H	19,7	6,2	11,0	3,3	7,1		6,0	5,0	1,2	2,8
08	M8 x 1,25	4H-5H	23,0	8,4	13,0	3,3	8,2	1,6	6,0	6,5	1,5	4,1
08F	M8 x 1	4H-5H										
10	M10 x 1,5	4H-5H	28,8	10,4	16,0	3,3	9,9		6,0	8,1	1,6	7,1
10F	M10 x 1,25	4H-5H										

cod. materiali material code	materiale material	finitura finish	durezza HR _C hardness HR _C	classe resistenza strenght class	classe temperatura temperature class
O300L	W1.7214.4 acciaio-steel	cadmiatura+MoS ₂ cadmium plating+MoS ₂	43 max.	900 MPa	235°C
O300C	25CrMo4	cadmiatura cadmium plating			235°C
O301X	W1.4944.4 lega A286 A286 alloy	passivazione passivation	27 min.		425°C
O301L		passivazione+MoS ₂ + puntino verde passivation+MoS ₂ + green dot			315°C
O301A		argentatura silver plating			425°C

FILETTO: profilo ISO 68; diam. foro filetto per filett. MJ ISO5855.
 MARCATURA: simbolo α del costruttore.
 NORMA di costruzione e controllo: LN65016.
 DESIGNAZIONE ASTORI: codice materiali-codice dimensioni.
 Esempio: O300C-05 indica una olivetta a disegno O300, in acciaio
 cadmiato, filettatura M5
 VARIAZIONI: aggiungere una K al codice dimensioni per le olivette
 con i fori di rivettatura svasati.

THREAD: profile ISO68; minor diam. according to MJ profile ISO 5855.
 MARKING: manufacturer symbol α
 PROCUREMENTS specification: LN65016.
 ASTORI CALL OUT: materials code-dimensions code.
 Example: O300C-5 designates a plate nut according to O300 drawing, in
 steel, cadmium plated, with M5 thread.
 VARIATIONS: add a K to dimensions code for plate nuts with countersunk
 rivet holes.

Reference L22553 LN29675	OLIVETTA AUTOFRENANTE AD ANGOLO, FISSA ANCHOR NUT, SELF-LOCKING CORNER, FIXED	O300 O301
--------------------------------	--	----------------------------