

THE INFORMATION AND DESIGN HEREIN WAS ORIGINATED BY AND IS THE PROPERTY OF SKYLOCK INDUSTRIES INCORPORATED. SKYLOCK INDUSTRIES INCORPORATED RESERVES ALL PATENT, PROPRIETARY, DESIGN MANUFACTURING, REPRODUCTION, USE AND SALES RIGHTS THERE TO, AND TO ANY ARTICLE DISCLOSED THEREIN EXCEPT TO THE EXTENT RIGHTS ARE EXPRESSLY GRANTED TO OTHERS. THE FOREGOING DOES NOT APPLY TO VENDOR PROPRIETARY PARTS.

REVISIONS				
ZONE	LTR	DESCRIPTION	DATE	APPROVED
	NC	PRODUCTION RELEASE	8-19-92	S. CSIK
	A	REVISED AND REDRAWN	8-20-92	T. CSIK
	B	ADDED -3 & -4	2-8-94	T. CSIK

- NOTES: UNLESS OTHERWISE SPECIFIED.
- REMOVE ALL BURRS AND BREAK SHARP EDGES.
 - MAT'L: RETAINER; ALUM. ALLOY, ALL OTHER PARTS; CRES.
 - FINISH: ALUM.; ANODIZE, CRES PARTS; PASSIVATE.
 - DECORATIVE FINISH: RETAINER; BRIGHT BUFF AND CANDY APPLE RED ANODIZE.
 - STATIC LOAD: 3000 LBS. MAX.
 - SHAFT NEEDS NO TORQUE ADJUSTMENT. TIGHTEN SHAFT AS MUCH AS POSSIBLE WHEN INSTALLING RETAINER.

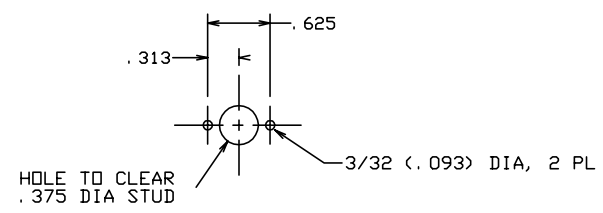
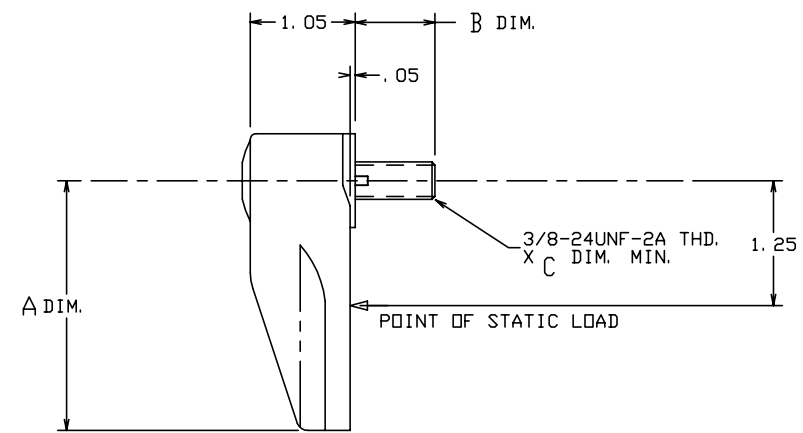
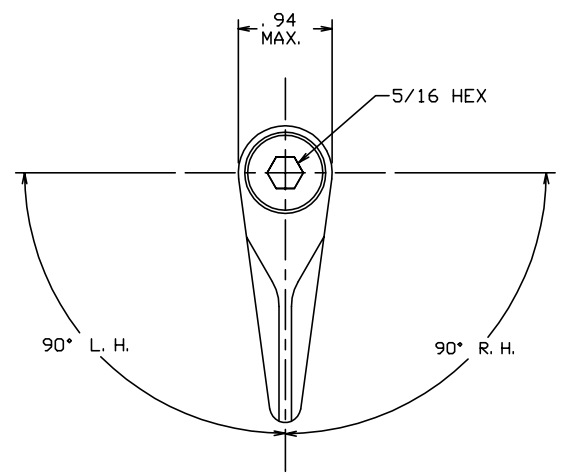

SUGGESTED PANEL CUTOUT

C DIM	B DIM	A DIM	PART NO.	DESCRIPTION	MATERIAL	SIZE	SPECIFICATION	ITEM NO.
.50	1.20	1.97	-4	RETAINER ASSY			<90° RIGHT HAND	
.50	1.20	1.97	-3	RETAINER ASSY			<90° LEFT HAND	
.80	.80	2.50	-2	RETAINER ASSY			<90° RIGHT HAND	
.80	.80	2.50	-1	RETAINER ASSY			<90° LEFT HAND	

PARTS LIST			
UNLESS OTHERWISE SPECIFIED	DRAWN BY	S. CSIK	8-19-92
DIMENSIONS ARE IN INCHES	CHECKED		
TOLERANCES ON	ENGINEER		
DECIMALS ANGLES DRILLED HOLES	PROJECT		
.X ± .1 ± 0° 30' AND 10387	APPROVAL	S. CSIK	8-19-92
.XX ± .03	APPROVAL		
.XXX ± .010			
DO NOT SCALE THIS DRAWING	USED ON		
MATERIAL - FINISH	SIZE	CODE IDENT. NO.	DRAWING NO.
NEXT ASSY	C	51941	20784
FINAL ASSY	SCALE	1: 1	WT.
			SHEET 1 OF 1

SKYLOCK INDUSTRIES INCORPORATED
MONROVIA CALIFORNIA U. S. A.

1/4 TURN RETAINER

REV. B