

THE INFORMATION AND DESIGN HEREIN WAS ORIGINATED BY AND IS THE PROPERTY OF SKYLOCK INDUSTRIES INCORPORATED. SKYLOCK INDUSTRIES INCORPORATED RESERVES ALL PATENT, PROPRIETARY, DESIGN MANUFACTURING, REPRODUCTION, USE AND SALES RIGHTS THERETO, AND TO ANY ARTICLE DISCLOSED THEREIN EXCEPT TO THE EXTENT RIGHTS ARE EXPRESSLY GRANTED TO OTHERS. THE FOREGOING DOES NOT APPLY TO VENDOR PROPRIETARY PARTS.

REVISIONS				
ZONE	LTR.	DESCRIPTION	DATE	APPROVED
	NC	PRODUCTION RELEASE	10.26.92	SC
	A	ADDED -3	10.28.92	SC

NOTES: UNLESS OTHERWISE SPECIFIED

1. REMOVE ALL BURRS AND SHARP EDGES
2. MAT'L: CASE AND BACKPLATE; ALUM ALLOY
3. FINISH: CASE; SATIN BRUSH AND CLEAR ANODIZE;
BACKPLATE: GEORGIAN GREY WRINKLE POWDER COAT,
MORTON 12-7002

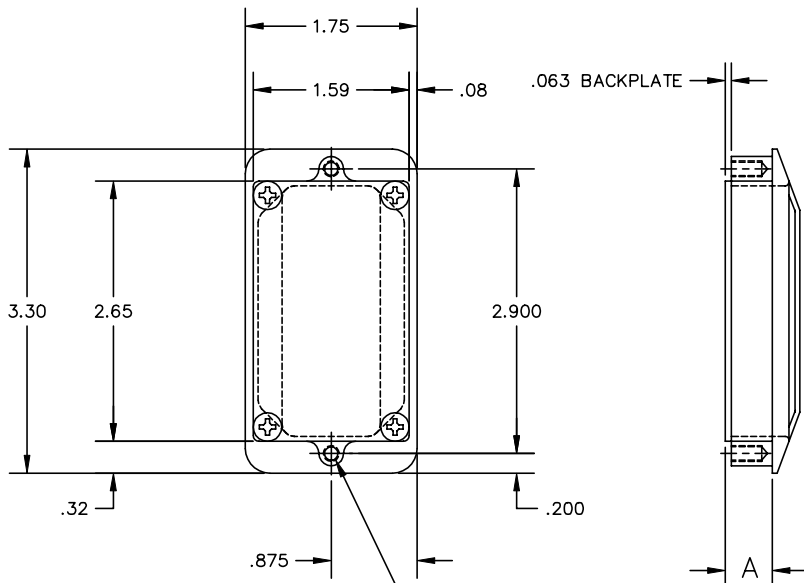

8-32 UNC SELF LOCKING THD
x .25 DP MIN
2 PLCS

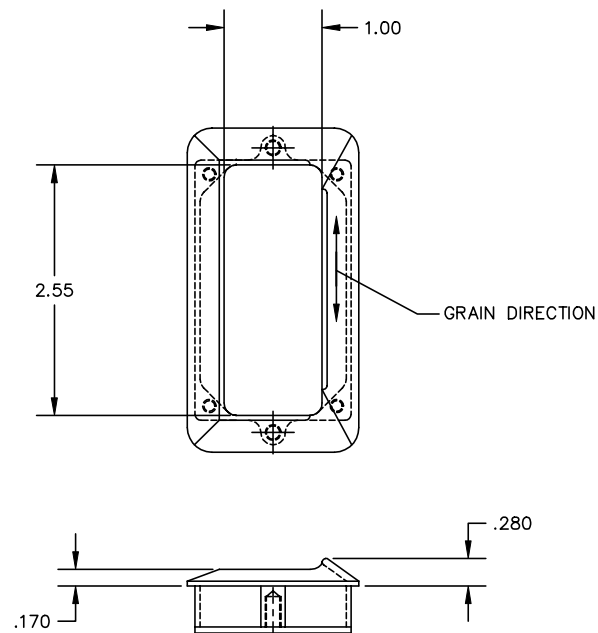

.73		-3	HANDLE ASSY			
.48		-1	HANDLE ASSY			
A	QTY. REQ'D	PART / IDENT NO.	DESCRIPTION	MATERIAL / SPECIFICATION	ITEM NO.	
	UNLESS OTHERWISE SPECIFIED: DIMENSIONS ARE IN INCHES		CONTRACT NO.	 SKYLOCK INDUSTRIES INCORPORATED MONROVIA, CALIFORNIA, USA		
	TOLERANCES		CUSTOMER			
	DECIMALS .XX ±.03 .XXX ±.010	ANGULAR ± 0 30'	DRAWN BY S. CSIK	DATE		
	DO NOT SCALE DRAWING		CHECK			
	NEXT ASSY	FINAL ASSY	DESIGN			
USED ON		DESIGN ACTIVITY	SIZE C	FSCM NO. 51941	DRAWING NO. 20777	REV. A
FINISH	ACT WT	CALC WT	SCALE 1/1	RELEASE DATE 7.1.92	SHEET 1 OF 1	

SHEET OF

DRAWING NO.

A