

THE INFORMATION AND DESIGN HEREIN WAS ORIGINATED BY AND IS THE PROPERTY OF SKYLOCK INDUSTRIES INCORPORATED. SKYLOCK INDUSTRIES INCORPORATED RESERVES ALL PATENT, PROPRIETARY, DESIGN MANUFACTURING, REPRODUCTION, USE AND SALES RIGHTS THERE TO, AND TO ANY ARTICLE DISCLOSED THEREIN EXCEPT TO THE EXTENT RIGHTS ARE EXPRESSLY GRANTED TO OTHERS. THE FOREGOING DOES NOT APPLY TO VENDOR PROPRIETARY PARTS.

REVISIONS				
ZONE	LTR	DESCRIPTION	DATE	APPROVED
	NC	PRODUCTION RELEASE	3-30-92	T. CSIK
	A	REVISED DIM. IS .56/.58 WAS .62	5-26-92	T. CSIK
	B	ADDED -403	7-16-92	T. CSIK
	C	ADDED -405	2-8-93	T. CSIK
	D	REVISED NOTE 5	7-10-97	T. CSIK
	E	SEE ECN E	3/5/99	T. CSIK

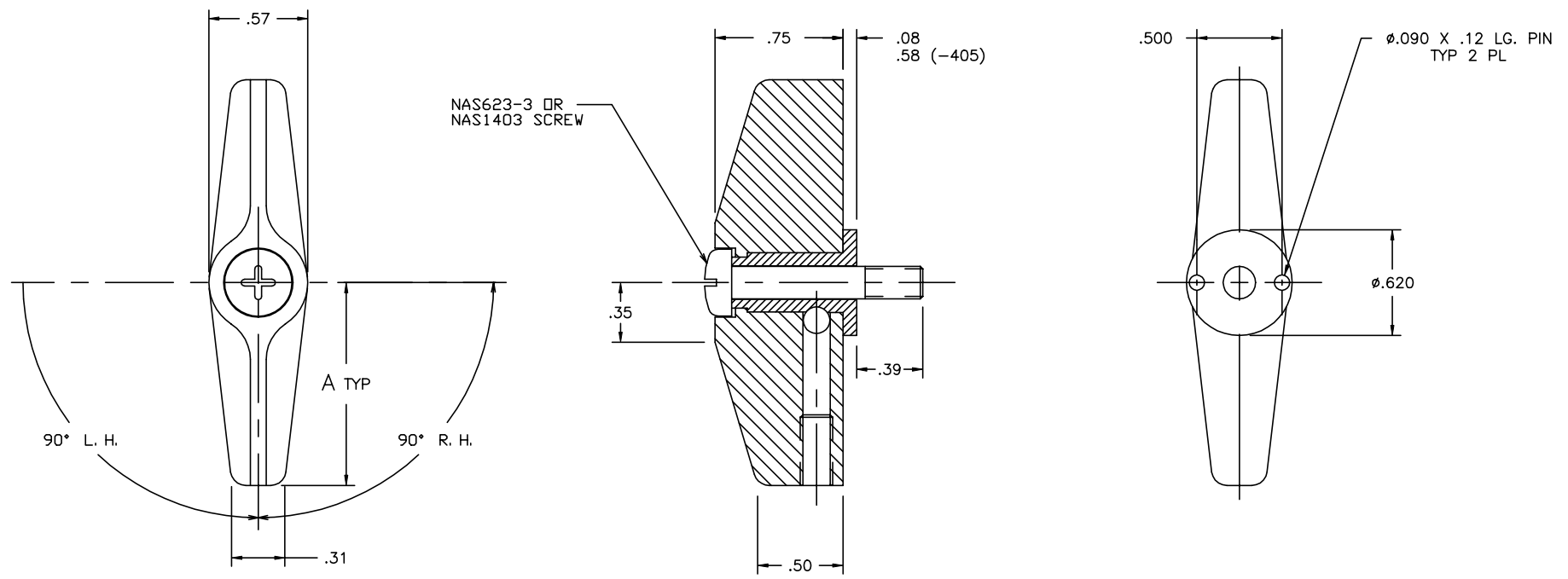

5. REMOVED
4. DECORATIVE FINISH: RETAINER; BRIGHT POLISH AND ANODIZE PER MIL-A-8625, TYPE II, CLASS 2, DYED CANDY APPLE RED.
3. FINISH: ALUM.; CLEAR ANODIZE PER MIL-A-8625, TYPE II, TYPE 1. CRES PARTS, PASSIVATE PER AMS-QQ-P-35, TYPE II.
2. MAT'L: RETAINER; ALUM. ALLOY, 7075-T6/T651 PER ASTM B-221 OR EQUIV. ALL OTHER PARTS; 303 CRES, CONDITION A, PER AMS-5640N OR EQUIV.
1. REMOVE ALL BURRS AND SHARP CORNERS

NOTES: UNLESS OTHERWISE SPECIFIED:

2.00	-405	RETAINER ASSY	(90° LEFT HAND)	
2.00	-403	RETAINER ASSY	(90° LEFT HAND)	
1.19	-402	RETAINER ASSY	(90° RIGHT HAND)	
1.19	-401	RETAINER ASSY	(90° LEFT HAND)	

PART NO.		DESCRIPTION	MATERIAL	SIZE	APPLICATION	ITEM NO.
PARTS LIST						
UNLESS OTHERWISE SPECIFIED		DRAWN BY	T. CSIK	3-30-92	 SKYLOCK INDUSTRIES INCORPORATED MONROVIA CALIFORNIA U. S. A.	
DIMENSIONS ARE IN INCHES		CHECKED	T. CSIK	3/5/99		
TOLERANCES ON		ENGINEER	T. CSIK	3/5/99		
DECIMALS ANGLES DRILLED HOLES		MFG P.	MATSUOKA	3/15/99		
.X .1 0° 30' AND 10387		Q. A.	J. VIVIRITO	3/18/99	1/4 TURN RETAINER	
.XX .03						
.XXX .010						
DO NOT SCALE THIS DRAWING						
MATERIAL - FINISH		USED ON	SIZE	CODE IDENT. NO.	DRAWING NO.	REV.
NEXT ASSY			C	51941	20766	E
FINAL ASSY			SCALE	2:1	WT.	SHEET 1 OF 1