

4

3

2

1

THE INFORMATION AND DESIGN HEREIN WAS ORIGINATED BY AND IS THE PROPERTY OF SKYLOCK INDUSTRIES INCORPORATED. SKYLOCK INDUSTRIES INCORPORATED RESERVES ALL PATENT, PROPRIETARY, DESIGN MANUFACTURING, REPRODUCTION, USE AND SALES RIGHTS THERE TO, AND TO ANY ARTICLE DISCLOSED THEREIN EXCEPT TO THE EXTENT RIGHTS ARE EXPRESSLY GRANTED TO OTHERS. THE FOREGOING DOES NOT APPLY TO VENDOR PROPRIETARY PARTS.

REVISIONS				
ZONE	LTR	DESCRIPTION	DATE	APPROVED
	E	REDRAWN	6-5-96	T. CSIK
	F	NOTE IS MS33656-4 WAS MS33656-3, TO AGREE WITH DRAWING PRIOR TO REV. E	6-25-98	T. CSIK
	G	SEE ECN G	7/27/99	T. CSIK

NOTES: UNLESS OTHERWISE SPECIFIED.

- MAT'L REF.: BODY, BUTTON & VALVE ASSY; 300 SERIES CRES., END FITTING; BRASS.
- DECORATIVE FINISH: SATIN BRUSH & PASSIVATE PER AMS-QQ-P-35 OR EQUIV.
- APPLICABLE TO FAA-PMA REPLACEMENT OR MODIFICATION PARTS ONLY.
PER FAR 45.15, PARTS WILL BE IDENTIFIED WITH:

- FAA-PMA.
- SKYLOCK IND. INC.
- PART NO.
- AIRCRAFT INSTALLATION ELIGIBILITY.

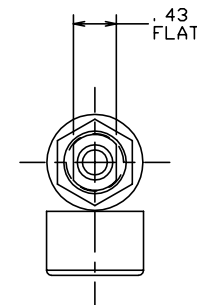
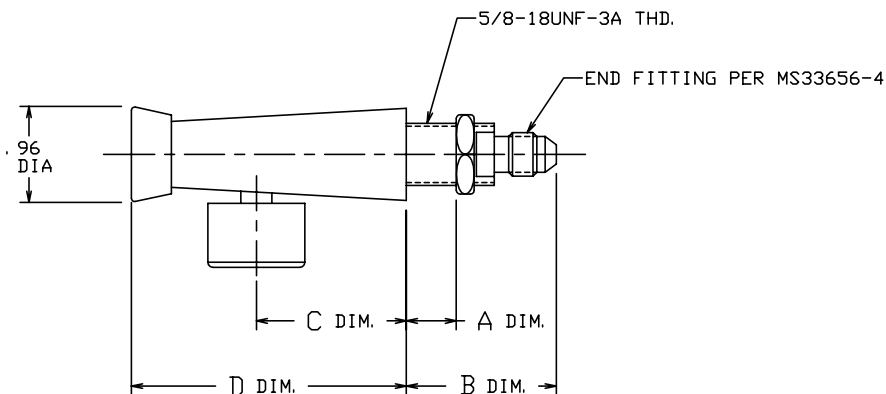
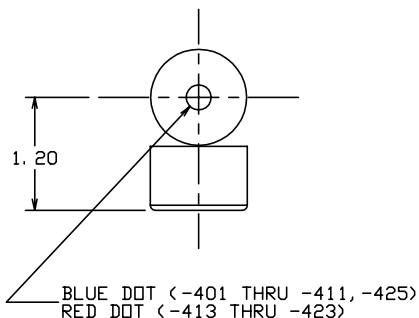

-401 THRU -425 SPIGOT

1.50	2.70	1.50	2.75	-425	SPIGOT ASSY		190043-425	
.50	1.70	3.50	4.75	-423	SPIGOT ASSY		190043-423	
.50	1.70	2.50	3.75	-421	SPIGOT ASSY		190043-421	
.25	1.50	1.50	2.75	-419	SPIGOT ASSY		190043-419	
1.00	2.20	1.50	2.75	-417	SPIGOT ASSY		190043-417	
.75	1.95	1.50	2.75	-415	SPIGOT ASSY		190043-415	
.50	1.70	1.50	2.75	-413	SPIGOT ASSY		190043-413	
.50	1.70	3.50	4.75	-411	SPIGOT ASSY		190043-411	
.50	1.70	2.50	3.75	-409	SPIGOT ASSY		190043-409	
.25	1.50	1.50	2.75	-407	SPIGOT ASSY		190043-407	
1.00	2.20	1.50	2.75	-405	SPIGOT ASSY		190043-405	
.75	1.95	1.50	2.75	-403	SPIGOT ASSY		190043-403	
.50	1.70	1.50	2.75	-401	SPIGOT ASSY		190043-401	
A	B	C	D	PART NO.	DESCRIPTION	MATERIAL	SIZE SPECIFICATION	MAKE FROM

PARTS LIST

UNLESS OTHERWISE SPECIFIED
DIMENSIONS ARE IN INCHES
TOLERANCES ON
DECIMALS ANGLES DRILLED HOLES
.X ± .1 ± 0° 30' AND 10387
.XX ± .03
.XXX ± .010

DRAWN BY T. S. 3-14-89
CHECKED L. GARCIA 6/16/99
ENGINEER T. CSIK 7/27/99
QC J. VIVIRITO 8/3/99
MFG P. MATSUOKA 8/3/99

SKYLOCK INDUSTRIES INCORPORATED
MONROVIA CALIFORNIA U. S. A.

SPIGOT

DO NOT SCALE THIS DRAWING	MATERIAL - FINISH	USED ON	SIZE	CODE IDENT. NO.	DRAWING NO.	REV.
			C	51941	90043	G
NEXT ASSY			MANUFACTURE IN ACCORDANCE WITH SKYLOCK IND. INC., QUALITY CONTROL MANUAL QC.001		SCALE 1/1	VT. SHEET 1 OF 1

FLUID MEDIA	TYPE	OPERATING PRESSURE	OPERATING TEMP.	FLOW
POTABLE WATER	SELF VENTING & BLEEDING	0-125 PSIG	35°F TO 225°F	100/140 OZ. /MIN. AT 70°F AND 30 P. S. I. INLET PRESSURE

4

3

2

1