

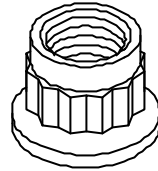

PAOLO ASTORI s.r.l.
via Gola 34 - MAGGIATE SUP.
I 28019-GATTICO (NO)

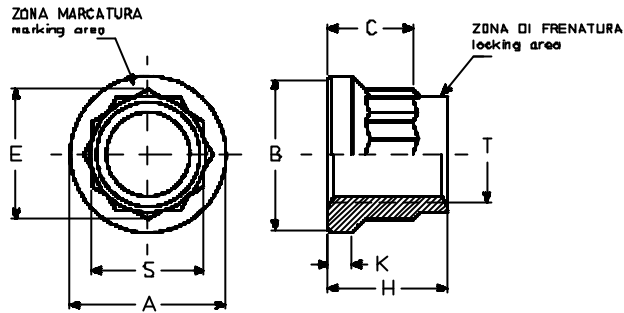

DP12
DP13



dimensioni in mm

| codice dimensioni | filettatura T | A h12 | B min. | C max. | E min. | H h14 | K min | S h12 |
|-------------------|-----------------|-------|--------|--------|--------|-------|-------|-------|
| 05 | MJ5x0,8 4H-6H | 9,1 | 8,3 | 4,9 | 7,8 | 7,0 | 1,2 | 7,0 |
| 06 | MJ6x1 4H-5H | 10,6 | 9,8 | 5,5 | 8,9 | 8,1 | | 8,0 |
| 07 | MJ7x1 4H-5H | 12,1 | 11,3 | 6,1 | 10,0 | 9,1 | | 9,0 |
| 08 | MJ8x1 4H-5H | 13,6 | 12,8 | 6,9 | 11,2 | 10,4 | | 10,0 |
| 10 | MJ10x1,25 4H-5H | 16,8 | 15,8 | 8,8 | 13,4 | 13,0 | | 12,0 |
| 12 | MJ12x1,25 4H-5H | 19,9 | 18,8 | 10,1 | 15,6 | 15,0 | 1,4 | 14,0 |
| 14 | MJ14x1,5 4H-5H | 23,0 | 21,9 | 12,6 | 18,9 | 17,5 | 1,7 | 17,0 |
| 16 | MJ16x1,5 4H-5H | 26,0 | 25,3 | 14,0 | 21,1 | 19,0 | 2,5 | 19,0 |
| 18 | MJ18x1,5 4H-5H | 29,0 | 28,3 | 16,0 | 24,5 | 22,0 | 3,0 | 22,0 |
| 20 | MJ20x1,5 4H-5H | 32,0 | 31,3 | 18,0 | 26,7 | 24,5 | 3,0 | 24,0 |

| codice materiali | materiale | finitura | classe resistenza | classe temperatura |
|------------------|---------------------------|---------------------------------|-------------------|--------------------|
| DP12L | NI-P100HT (INCONEL718) | lubrificazione MoS ₂ | 1550 MPa | 425°C |
| DP13A | | argentatura | | 600°C |

FILETTATURA: profilo ISO5855
NORMA DI COSTRUZIONE E CONTROLLO : EN4047

DESIGNAZIONE ASTORI: codice materiali-codice dimensioni.
Esempio: DP12L-5 indica un dado a disegno DP12, in Inconel 718 , filettatura MJ5x0,8 4H-6H , lubrificato con MoS₂.

Riferimenti
EN4011
EN4012
(fino al diam. 14)

DADO A 12 PUNTE, AUTOFREANANTE
CLASSE 1550 MPa

DP12
DP13