

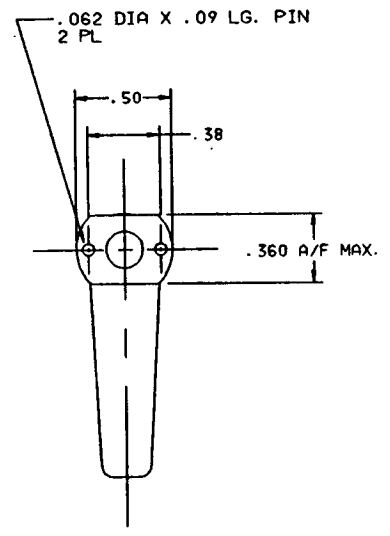

4
 THE INFORMATION AND DESIGN HEREIN WAS ORIGINATED BY AND IS THE PROPERTY OF SKYLOCK INDUSTRIES, INCORPORATED. SKYLOCK INDUSTRIES INCORPORATED RESERVES ALL PATENT, PROPRIETARY, DESIGN, MANUFACTURING, REPRODUCTION, USE AND SALES RIGHTS THEREON, AND TO ANY ARTICLE DISCLOSED THEREIN EXCEPT TO THE EXTENT RIGHTS ARE EXPRESSLY GRANTED TO OTHERS. THE FOREGOING DOES NOT APPLY TO VENDOR PROPRIETARY PARTS.

- NOTES: UNLESS OTHERWISE SPECIFIED.
1. REMOVE ALL BURRS AND BREAK SHARP EDGES.
 2. MAT'L: ALL COMPONENTS: CRES.
 3. FINISH: CLEAN AND PASSIVATE.
 4. DECORATIVE FINISH: SATIN BRUSH APPEARANCE SURFACES.
 5. STATIC LOAD: 600 LBS. MAX.

REVISIONS				
ZONE	LTR	DESCRIPTION	DATE	APPROVED
	NC	PRODUCTION RELEASE	8-16-91	T. CSIK
	A	REVISED AND REDRAWN	8-29-91	T. CSIK

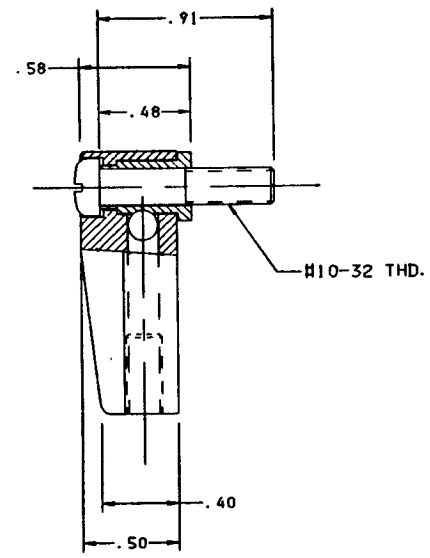
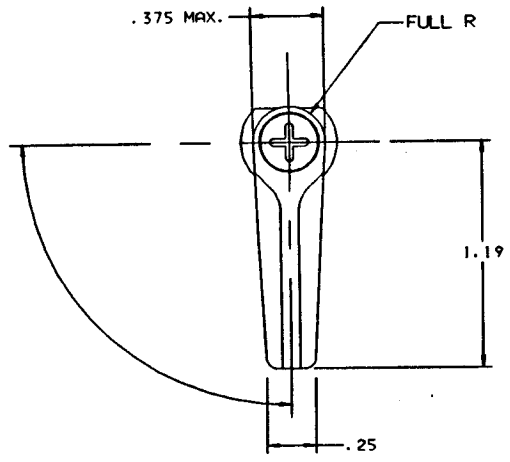

	-2	RETAINER	OPP. -1 (ROTATION: 90° R.H.)			
	-1	RETAINER	SHOWN (ROTATION: 90° L.H.)			
QTY REQD	PART NO.	DESCRIPTION	MATERIAL	SIZE	SPECIFICATION	ITEM NO.
PARTS LIST						
UNLESS OTHERWISE SPECIFIED		DRAWN BY	T. CSIK	9-10-91	 SKYLOCK INDUSTRIES INCORPORATED MONROVIA CALIFORNIA U.S.A.	
DIMENSIONS ARE IN INCHES		CHECKED				
TOLERANCES ON		DATE				
DECIMALS ANGLES DRILLED HOLES		PROJECT				
.X .X .1 ± 0° 30' AND 10007		APPROVAL	T. CSIK	9-10-91	1/4 TURN RETAINER	
.XX .X .02		APPROVAL				
.XXX .010		MATERIAL - FINISH	USED ON	SIZE	CODE IDENT. NO.	DRAWING NO.
DO NOT SCALE THIS DRAWING				C	51941	20722
NEXT ASSY				SCALE	2:1	WT.
FINAL ASSY						SHEET 1 OF 1