

THE INFORMATION AND DESIGN HEREIN WAS ORIGINATED BY AND IS THE PROPERTY OF SKYLOCK INDUSTRIES INCORPORATED. SKYLOCK INDUSTRIES INCORPORATED RESERVES ALL PATENT, PROPRIETARY, DESIGN MANUFACTURING, REPRODUCTION, USE AND SALES RIGHTS THEREON, AND TO ANY ARTICLE DISCLOSED THEREIN EXCEPT TO THE EXTENT RIGHTS ARE EXPRESSLY GRANTED TO OTHERS. THE FOREGOING DOES NOT APPLY TO VENDOR PROPRIETARY PARTS.

REVISIONS				
ZONE	LTR.	DESCRIPTION	DATE	APPROVED
	NC	PRODUCTION RELEASE	10.7.92	SC

NOTES: UNLESS OTHERWISE SPECIFIED

- REMOVE ALL BURRS AND SHARP EDGES
- MAT'L: BRACKETS, HOOK, RIVETS; 2024-T3/T4 ALUM ALLOY; SPRING; CRES; ALL OTHER COMPONENTS; STEEL
- FINISH: ALUM; CLEAR ANODIZE; CRES; PASSIVATE; STEEL; CAD PLATE
- APPROX .25 LB WILL INITIATE DISENGAGEMENT OF HOOK

DASH NO.	A	B	C
-401	2.06	1.81	1.66

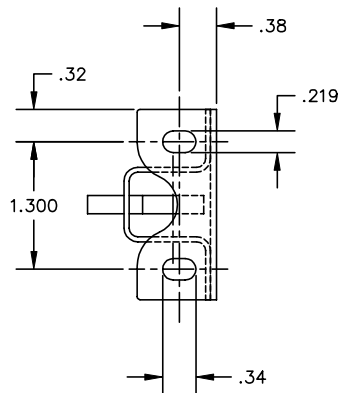
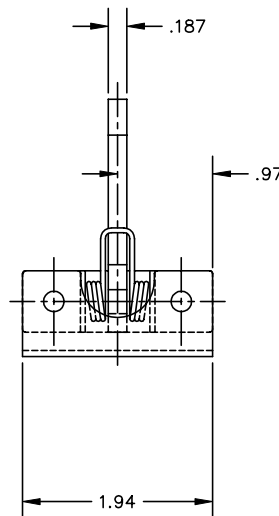
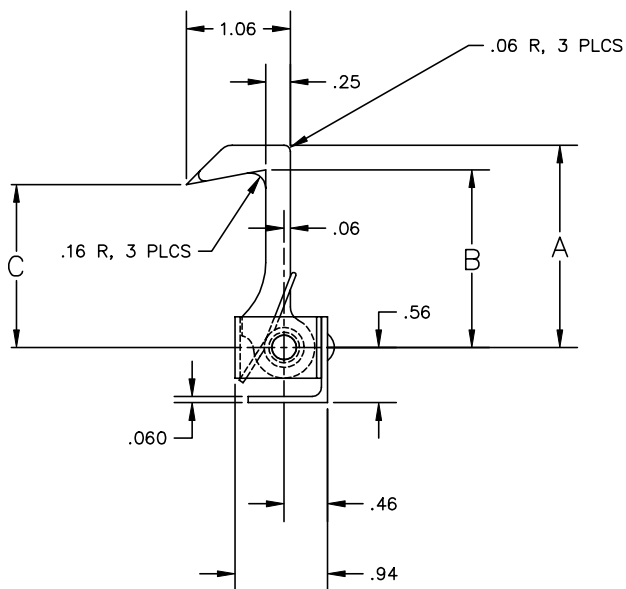

-401		LATCH ASSY			
QTY. REQ'D	PART / IDENT NO.	DESCRIPTION	MATERIAL / SPECIFICATION		ITEM NO.
UNLESS OTHERWISE SPECIFIED: DIMENSIONS ARE IN INCHES		CONTRACT NO.	SKYLOCK INDUSTRIES INCORPORATED MONROVIA, CALIFORNIA, USA		
TOLERANCES		CUSTOMER	LATCH ASSY, HOOK		
DECIMALS	ANGULAR	DRAWN BY	DATE		
.XX ±.03	± 0 30'	S. CSIK			
.XXX ±.010		CHECK			
DO NOT SCALE DRAWING		DESIGN KEY			
NEXT ASSY	FINAL ASSY	DESIGN ACTIVITY	SIZE	FSCM NO.	DRAWING NO.
USED ON			C	51941	20794
FINISH	ACT WT	CALC WT	SCALE	RELEASE DATE	SHEET
			1/1	10.7.92	1 OF 1

DRAWING NO.

SHEET OF

A