

THE INFORMATION AND DESIGN HEREIN WAS ORIGINATED BY AND IS THE PROPERTY OF SKYLOCK INDUSTRIES INCORPORATED. SKYLOCK INDUSTRIES INCORPORATED RESERVES ALL PATENT, PROPRIETARY, DESIGN MANUFACTURING, REPRODUCTION, USE AND SALES RIGHTS THERETO, AND TO ANY ARTICLE DISCLOSED THEREIN EXCEPT TO THE EXTENT RIGHTS ARE EXPRESSLY GRANTED TO OTHERS. THE FOREGOING DOES NOT APPLY TO VENDOR PROPRIETARY PARTS.

REVISIONS				
ZONE	LTR.	DESCRIPTION	DATE	APPROVED
	NC	PRODUCTION RELEASE	9.21.91	SC

NOTES: UNLESS OTHERWISE SPECIFIED

1. REMOVE ALL BURRS AND SHARP EDGES
2. MAT'L: CASE AND BACKPLATE; ALUM ALLOY
3. FINISH: SATIN BRUSH AND CLEAR ANODIZE PER MIL-A-8625E

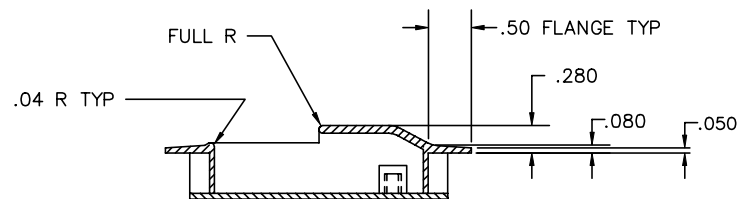
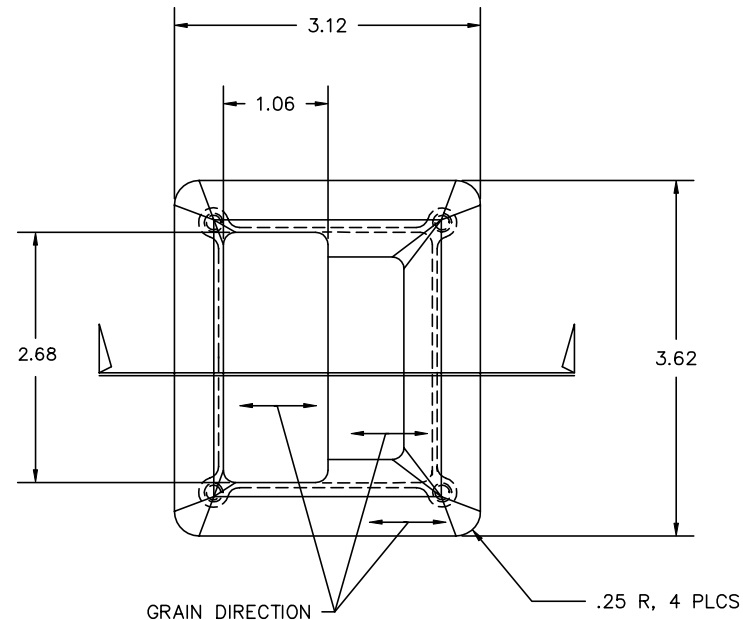
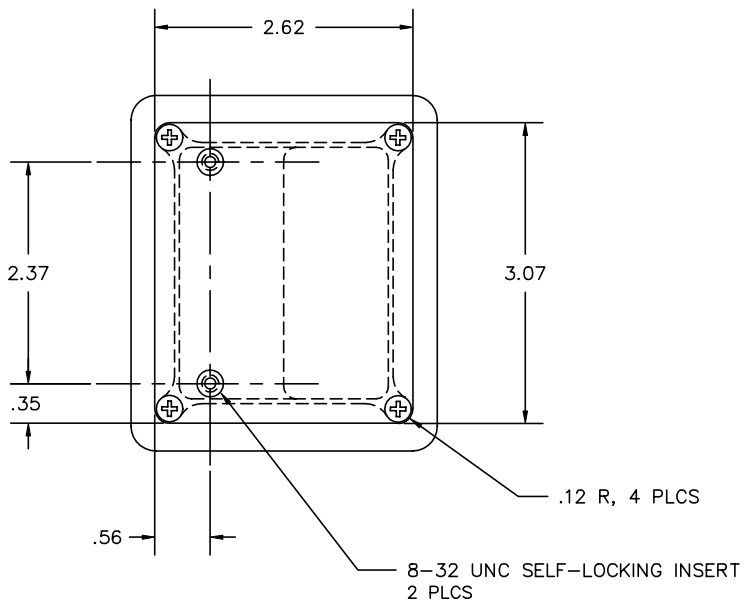

.68		-3	HANDLE ASSY		
.48		-1	HANDLE ASSY		
A	QTY. REQ'D	PART / IDENT NO.	DESCRIPTION	MATERIAL / SPECIFICATION	ITEM NO.
	UNLESS OTHERWISE SPECIFIED: DIMENSIONS ARE IN INCHES		CONTRACT NO.	 SKYLOCK INDUSTRIES INCORPORATED MONROVIA, CALIFORNIA, USA	A
TOLERANCES		CUSTOMER	 SKYLOCK INDUSTRIES INCORPORATED MONROVIA, CALIFORNIA, USA		
DECIMALS .XX ±.03		ANGULAR ± 0 30'	DRAWN BY S. CSIK	DATE	<h1>HANDLE ASSY</h1>
DO NOT SCALE DRAWING		CHECK			
NEXT ASSY		FINAL ASSY	DESIGN		
USED ON		DESIGN ACTIVITY		SIZE C	REV. NC
FINISH		ACT WT	CALC WT	FSCM NO. 51941	DRAWING NO. 20732
				SCALE 1/1	RELEASE DATE 9.21.91 SHEET 1 OF 1