

THE INFORMATION AND DESIGN HEREIN WAS ORIGINATED BY AND IS THE PROPERTY OF SKYLOCK INDUSTRIES INCORPORATED. SKYLOCK INDUSTRIES INCORPORATED RESERVES ALL PATENT, PROPRIETARY, DESIGN MANUFACTURING, REPRODUCTION, USE AND SALES RIGHTS THERE TO, AND TO ANY ARTICLE DISCLOSED THEREIN EXCEPT TO THE EXTENT RIGHTS ARE EXPRESSLY GRANTED TO OTHERS. THE FOREGOING DOES NOT APPLY TO VENDOR PROPRIETARY PARTS.

REVISIONS				
ZONE	LTR	DESCRIPTION	DATE	APPROVED
	NC	PRODUCTION RELEASE	10-19-93	T. CSIK
	A	ADDED -405, -407	10-20-93	T. CSIK
	B	SHT. 2, -407, REVISED DIM'S PER CUSTOMER REQUEST, IS .63 (-407) WAS .73 (-407), IS .38 2 PL WAS .31 2 PL, IS .88 2 PL WAS .84 2 PL, IS ... CSK 100" X .279 DIA WAS ... CSK 100" X .265 DIA	1-5-94	T. CSIK

- NOTES: UNLESS OTHERWISE SPECIFIED.
1. REMOVE ALL BURRS AND BREAK SHARP EDGES.
  2. MAT'L: 6061-T6 ALUM ALLOY.
  3. FINISH: SATIN BUFF AND CLEAR ANODIZE.

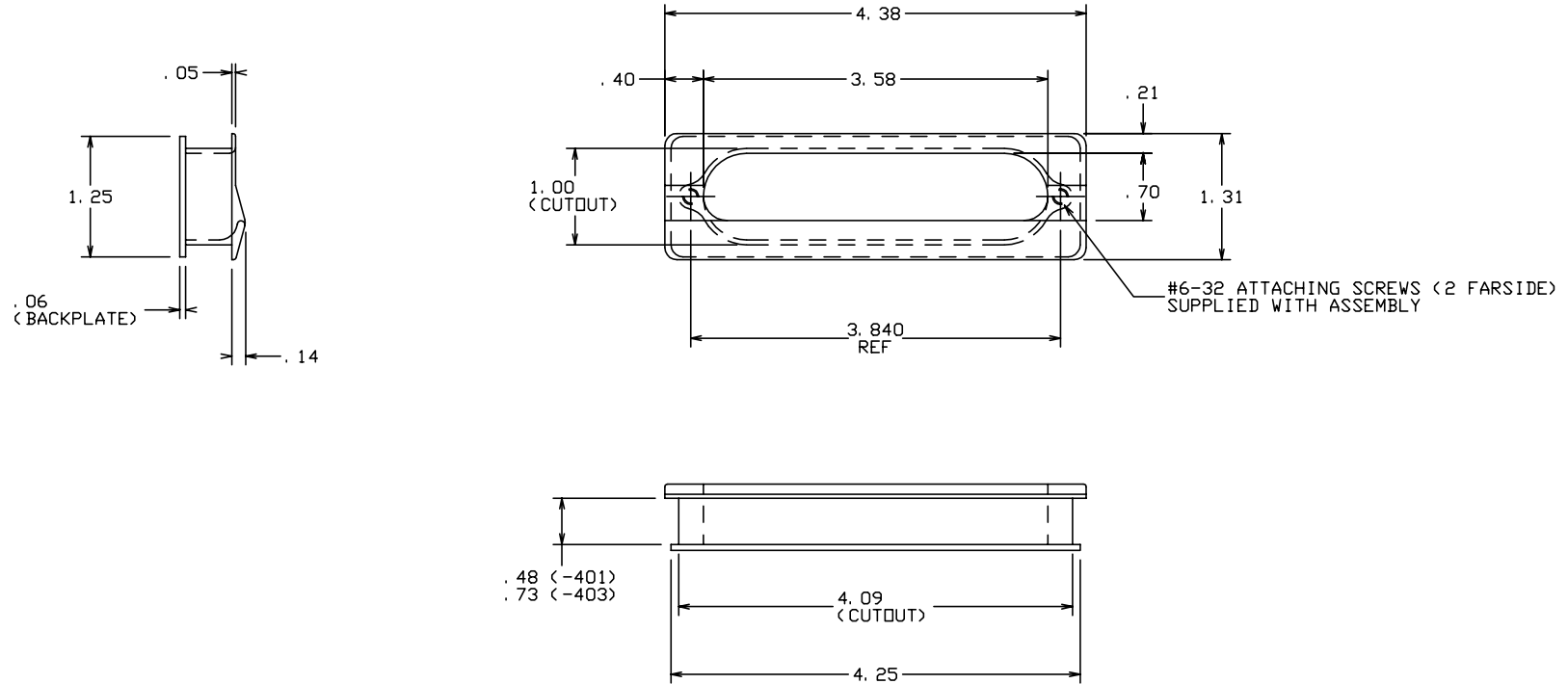

-401 HANDLE ASSY  
-403 HANDLE ASSY

	-407	HANDLE ASSY				
	-405	HANDLE ASSY				
	-403	HANDLE ASSY				
	-401	HANDLE ASSY				
QTY REQD	PART NO.	DESCRIPTION	MATERIAL	SIZE	SPECIFICATION	ITEM NO.
PARTS LIST						
UNLESS OTHERWISE SPECIFIED		DRAWN BY	T. CSIK	10-18-93	 SKYLOCK INDUSTRIES INCORPORATED MONROVIA CALIFORNIA U. S. A.	
DIMENSIONS ARE IN INCHES		CHECKED				
TOLERANCES ON		ENGINEER				
DECIMALS ANGLES DRILLED HOLES		PROJECT				
.X ± .1 ± 0° 30' AND 10387		APPROVAL	T. CSIK	10-18-93	HANDLE ASSY	
.XX ± .03		APPROVAL				
.XXX ± .010		DO NOT SCALE THIS DRAWING				
MATERIAL - FINISH		USED ON		SIZE	CODE IDENT. NO.	DRAWING NO.
NEXT ASSY				C	51941	20867
FINAL ASSY				SCALE	1:2	WT.
						SHEET 1 OF 2

4

3

2

1

REVISIONS				DATE	APPROVED
ZONE	LTR	DESCRIPTION			
		SEE SHT. 1 FOR NOTES			

.140 DIA THRU HOLE  
 CSK 100° X .279 DIA FAR SIDE  
 TYP 2 PLCS < INSIDE > (-407 ONLY)

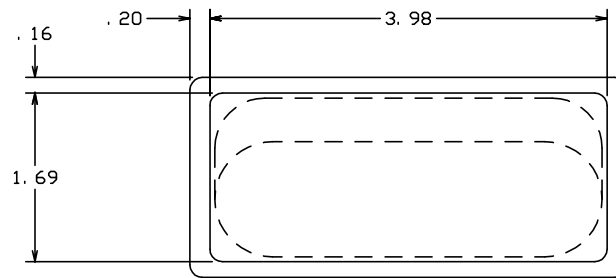
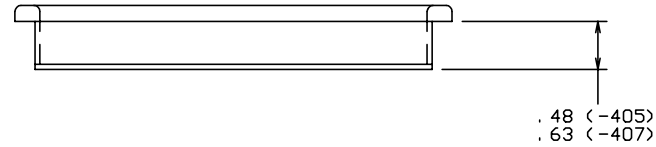
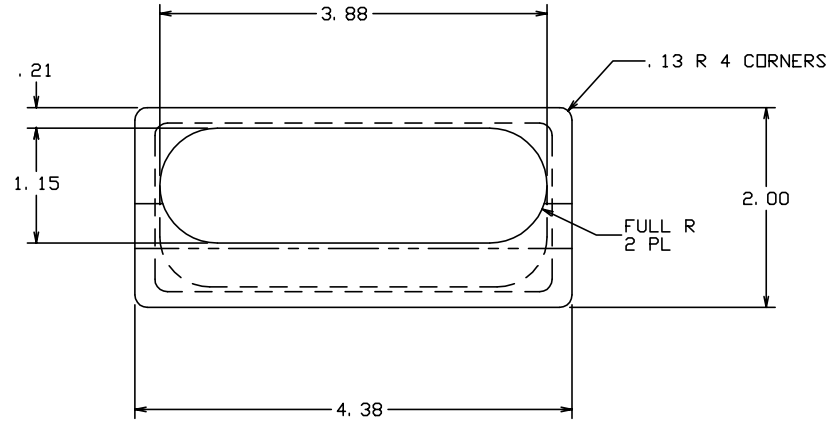
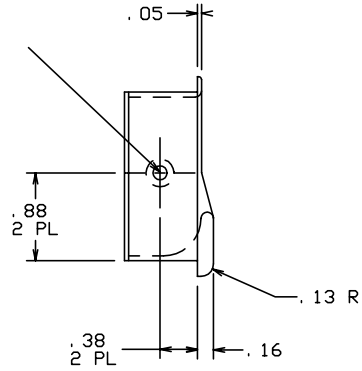

-405 HANDLE ASSY  
-407 HANDLE ASSY

SKYLOCK INDUSTRIES INCORPORATED  
 MONROVIA CALIFORNIA U. S. A.

HANDLE ASSY

SIZE	CODE IDENT. NO.	DRAWING NO.	REV.
C	51941	20867	B
SCALE 1: 2	VT.	SHEET 2	OF 2

4

3

2

1