

THE INFORMATION AND DESIGN HEREIN WAS ORIGINATED BY AND IS THE PROPERTY OF SKYLOCK INDUSTRIES INCORPORATED. SKYLOCK INDUSTRIES INCORPORATED RESERVES ALL PATENT, PROPRIETARY, DESIGN MANUFACTURING, REPRODUCTION, USE AND SALES RIGHTS THERE TO, AND TO ANY ARTICLE DISCLOSED THEREIN EXCEPT TO THE EXTENT RIGHTS ARE EXPRESSLY GRANTED TO OTHERS. THE FOREGOING DOES NOT APPLY TO VENDOR PROPRIETARY PARTS.

REVISIONS				
ZONE	LTR	DESCRIPTION	DATE	APPROVED
	NC	PRODUCTION RELEASE	8-25-93	T. CSIK
	A	REVISED PART NO. , -1 WAS -3, -2 WAS -4	10-27-93	T. CSIK
	B	ADDED -3, -4	1-11-94	T. CSIK

- NOTES: UNLESS OTHERWISE SPECIFIED.
1. REMOVE ALL BURRS AND BREAK SHARP EDGES.
  2. MAT'L: RETAINER; ALUM. ALLOY, ALL OTHER PARTS; 300 SERIES CRES.
  3. FINISH: ALUM.; ANODIZE, CRES PARTS; PASSIVATE.
  4. DECORATIVE FINISH: RETAINER; BRIGHT BUFF AND CANDY APPLE RED ANODIZE.
  5. STATIC LOAD: 600 LBS. MAX.

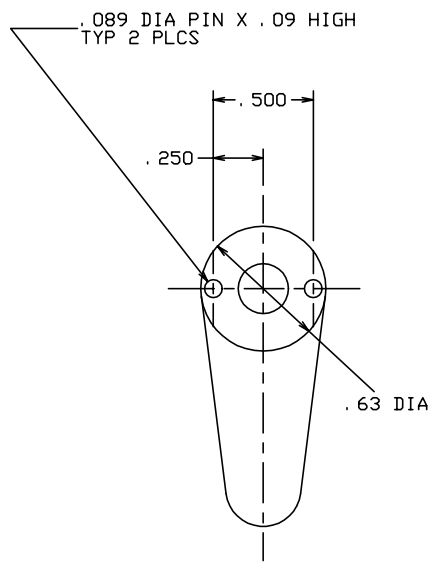
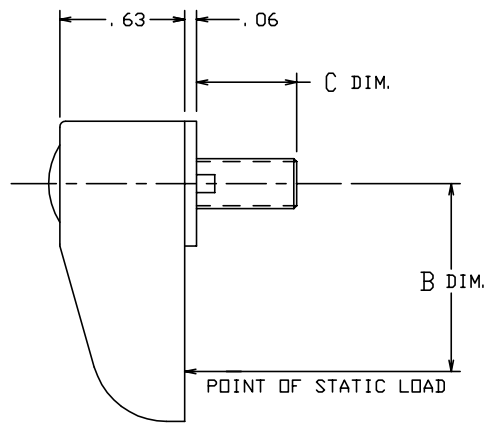
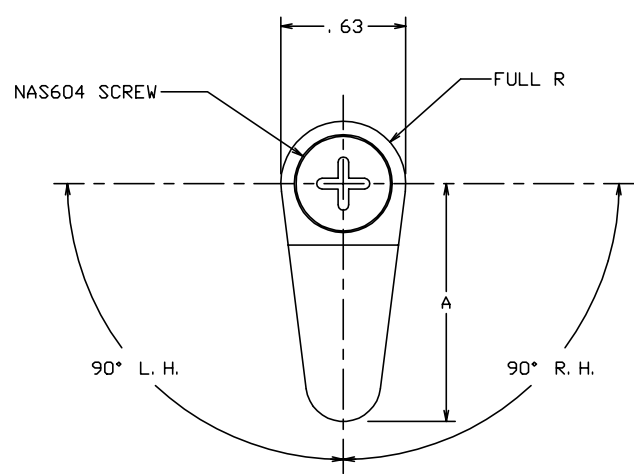

C DIM	B DIM	A DIM	PART NO.	DESCRIPTION	MATERIAL	SIZE	SPECIFICATION	ITEM NO.
.50	1.72	1.97	-4	1/4 TURN				<90° RIGHT HAND
.50	1.72	1.97	-3	1/4 TURN				<90° LEFT HAND
.50	.94	1.19	-2	1/4 TURN				<90° RIGHT HAND
.50	.94	1.19	-1	1/4 TURN				<90° LEFT HAND

**PARTS LIST**

UNLESS OTHERWISE SPECIFIED	DRAWN BY	T. CSIK	8-25-93	 SKYLOCK INDUSTRIES INCORPORATED MONROVIA CALIFORNIA U. S. A.			
DIMENSIONS ARE IN INCHES	CHECKED						
TOLERANCES ON	ENGINEER						
DECIMALS ANGLES DRILLED HOLES	PROJECT						
.X ± .1 ± 0° 30' AND 10387	APPROVAL	T. CSIK	8-25-93	<b>1/4 TURN RETAINER</b>			
.XX ± .03	APPROVAL						
.XXX ± .010							
DO NOT SCALE THIS DRAWING	USED ON						
MATERIAL - FINISH	USED ON			SIZE	CODE IDENT. NO.	DRAWING NO.	REV.
NEXT ASSY				C	51941	20852	B
FINAL ASSY				SCALE	2: 1	VT.	SHEET 1 OF 1