

4

3

2

1

THE INFORMATION AND DESIGN HEREIN WAS ORIGINATED BY AND IS THE PROPERTY OF SKYLOCK INDUSTRIES INCORPORATED. SKYLOCK INDUSTRIES INCORPORATED RESERVES ALL PATENT, PROPRIETARY, DESIGN MANUFACTURING, REPRODUCTION, USE AND SALES RIGHTS THERE TO, AND TO ANY ARTICLE DISCLOSED THEREIN EXCEPT TO THE EXTENT RIGHTS ARE EXPRESSLY GRANTED TO OTHERS. THE FOREGOING DOES NOT APPLY TO VENDOR PROPRIETARY PARTS.

REVISIONS				
ZONE	LTR	DESCRIPTION	DATE	APPROVED
	NC	PRODUCTION RELEASE	3/22/99	T. CSIK

NOTES: UNLESS OTHERWISE SPECIFIED.

1. REMOVE ALL BURRS AND BREAK SHARP EDGES.
2. MAT'L REFERENCE: RETAINER, BLOCK, PLATE, CAM; ALUM. ALLOY, COVER; BOLTARDN OR EQUIV., STUD, SHAFT, THREADED PIN; ST. STL.
3. REFERENCE FINISH: RETAINER; POLISH, AND CANDY APPLE RED ANODIZE, PLATE, CAM; CLEAR ANODIZE, BLOCK; HARD ANODIZE, STUD; HEAT TREAT, SHAFT; HEAT TREAT AND CADMIUM PLATE.
4. THE FOLLOWING STATIC LOAD TEST DATA IS FOR REFERENCE USE ONLY. IT IS PROVIDED FOR CUSTOMER ENGINEERING TO DETERMINE THE GENERAL SUITABILITY OF THE PRODUCT FOR ITS INTENDED USE. ALTHOUGH SKYLOCK IS PROVIDING THE REFERENCE TEST DATA, THE CUSTOMER IS ULTIMATELY RESPONSIBLE FOR LOAD TEST CERTIFICATION OF THE PRODUCT FOR ITS INTENDED APPLICATION AND INSTALLATION. REFERENCE STATIC LOAD: 2745 LBS. .75' FROM RETAINER TIP AT EXTENDED POSITION. REFER TO DWG. TS20956 FOR TEST REQUIREMENTS.
5. RETAINER IS DETENTED AT EACH 90° OF ROTATION.

-402	RETAINER ASSY		120956-402
-401	RETAINER ASSY		120956-401
			MAKE FROM RETAINER ASSEMBLY
PART NO.	DESCRIPTION	MATERIAL SIZE SPECIFICATION	
PARTS LIST			
UNLESS OTHERWISE SPECIFIED	DRAWN BY T. CSIK	11-17-98	 SKYLOCK INDUSTRIES INCORPORATED MONROVIA CALIFORNIA U. S. A.
DIMENSIONS ARE IN INCHES	CHECKED E. WELSH	3/22/99	
TOLERANCES ON	ENGINEER T. CSIK	3/22/99	
DECIMALS ANGLES DRILLED HOLES	MFG P. MATSUOKA	3/22/99	
.X ± .1 ± 0° 30' AND 10367	QC J. VIVIRITO	3/22/99	
.XX ± .03			
.XXX ± .010			
DO NOT SCALE THIS DRAWING			
		SIZE C	CODE IDENT. NO. 51941
			DRAWING NO. 20956
			REV. NC
MANUFACTURE IN ACCORDANCE WITH SKYLOCK QUALITY CONTROL MANUAL QC.001		SCALE NONE	SHEET 1 OF 2

4

3

2

1

THE INFORMATION AND DESIGN HEREIN WAS ORIGINATED BY AND IS THE PROPERTY OF SKYLOCK INDUSTRIES INCORPORATED. SKYLOCK INDUSTRIES INCORPORATED RESERVES ALL PATENT, PROPRIETARY, DESIGN MANUFACTURING, REPRODUCTION, USE AND SALES RIGHTS THERE TO, AND TO ANY ARTICLE DISCLOSED THEREIN EXCEPT TO THE EXTENT RIGHTS ARE EXPRESSLY GRANTED TO OTHERS. THE FOREGOING DOES NOT APPLY TO VENDOR PROPRIETARY PARTS.

REVISIONS				
ZONE	LTR	DESCRIPTION	DATE	APPROVED
		SEE SHT. 1 FOR NOTES		

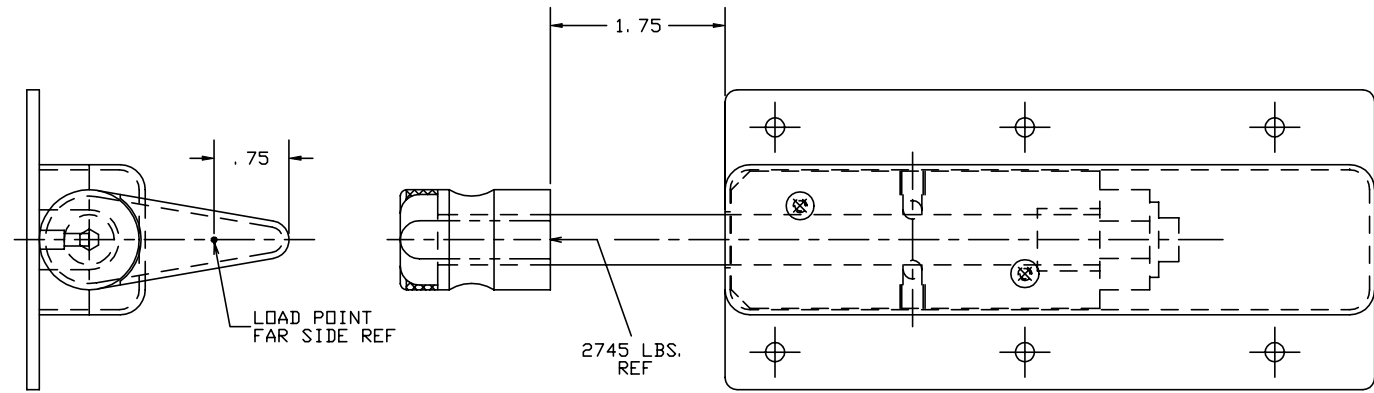

(EXTENDED/DETENTED POSITION SHOWN)

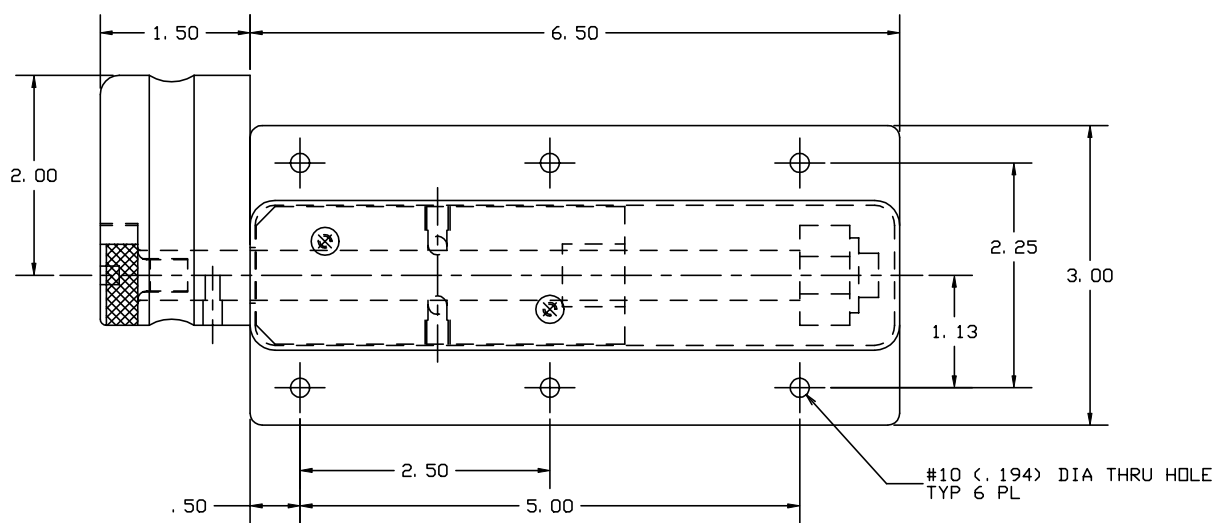
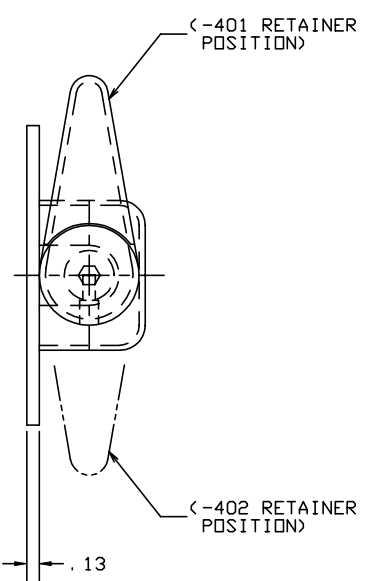

(RETRACTED/DETENTED/SPRING RETURN POSITION SHOWN)

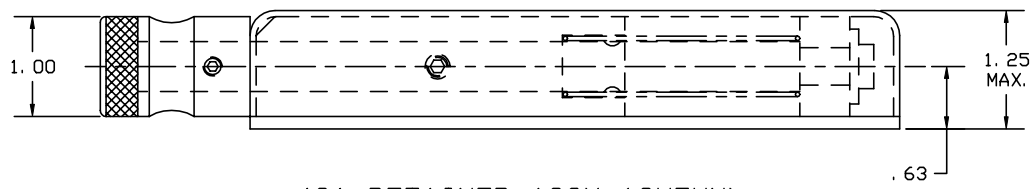

-401 RETAINER ASSY (SHOWN)
 -402 RETAINER ASSY (SAME AS -401 EXCEPT CAM AND RETAINER ORIENTATION)

SKYLOCK INDUSTRIES INCORPORATED
 MONROVIA CALIFORNIA U. S. A.

RETAINER ASSY

SIZE C	CODE IDENT. NO. 51941	DRAWING NO. 20956	REV. NC
SCALE 1: 1	VT.	SHEET 2	OF 2