

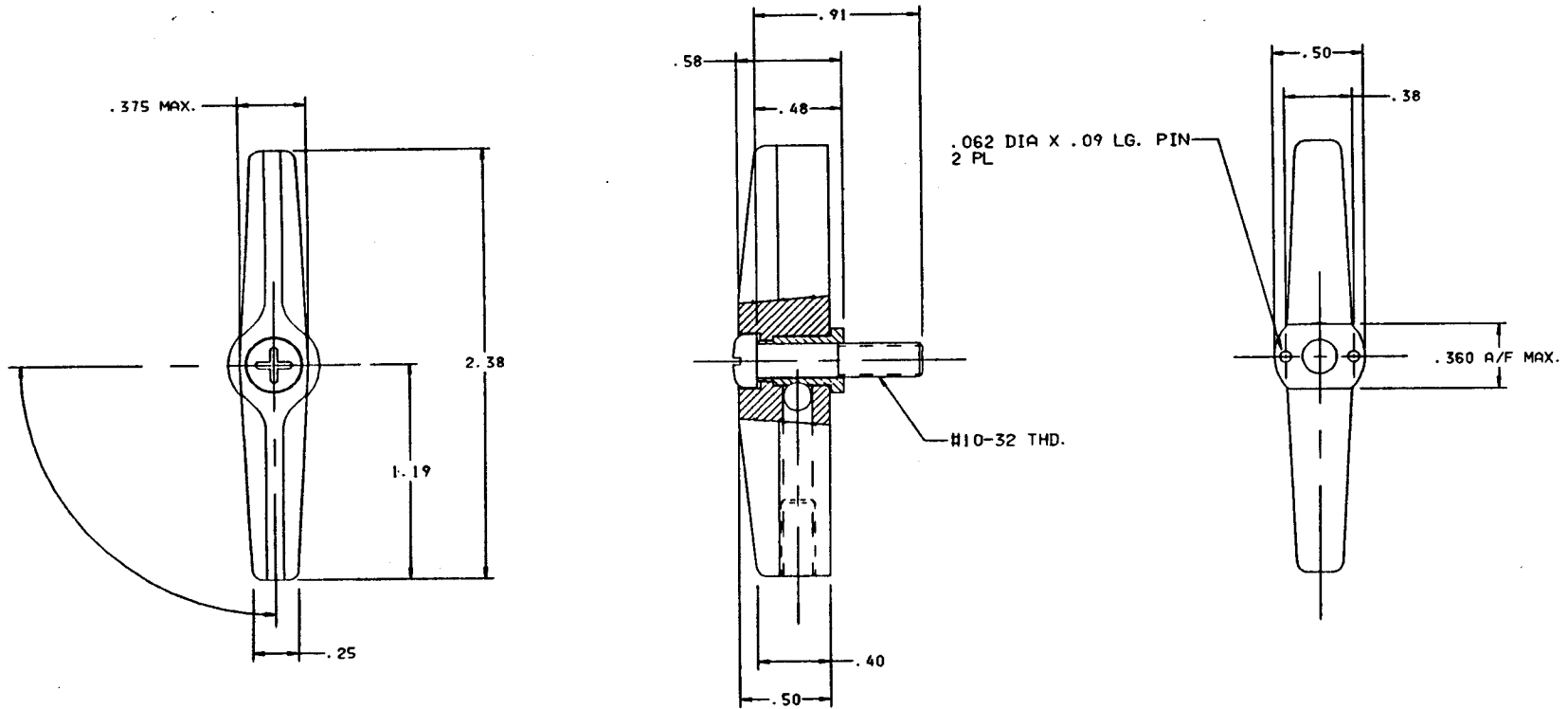

4
 3
 2
 1
 THE INFORMATION HEREIN WAS ORIGINATED BY AND IS THE PROPERTY OF SKYLOCK INDUSTRIES INCORPORATED. SKYLOCK INDUSTRIES INCORPORATED RESERVES ALL PATENT, PROPRIETARY, DESIGN MANUFACTURING, REPRODUCTION, USE AND SALES RIGHTS THEREIN, AND TO ANY ARTICLE DISCLOSED THEREIN EXCEPT TO THE EXTENT RIGHTS ARE EXPRESSLY GRANTED TO OTHERS. THE FOREGOING DOES NOT APPLY TO VENDOR PROPRIETARY PARTS.

REVISIONS				
ZONE	LTR	DESCRIPTION	DATE	APPROVED
	NC	PRODUCTION RELEASE	9-6-91	T. CSIK

NOTES: UNLESS OTHERWISE SPECIFIED.

1. REMOVE ALL BURRS AND BREAK SHARP EDGES.
2. MAT'L: ALL COMPONENTS: CRES.
3. FINISH: CLEAN AND PASSIVATE.
4. DECORATIVE FINISH: SATIN BRUSH APPEARANCE SURFACES.
5. STATIC LOAD: 600 LBS. MAX.



-1		RETAINER	SHOWN (ROTATION: 90° L.H.)		ITEM NO.
QTY REQD	PART NO.	DESCRIPTION	MATERIAL	SIZE SPECIFICATION	
PARTS LIST					
UNLESS OTHERWISE SPECIFIED		DRAWN BY T. CSIK	9-9-91	 SKYLOCK INDUSTRIES INCORPORATED MONROVIA CALIFORNIA U.S.A.	
DIMENSIONS ARE IN INCHES		CHECKED			
TOLERANCES ON		ENGINEER			
DECIMALS ANGLES DRILLED HOLES		PROJECT			
.XX ± .01 ± 0° 50' AND 10597		APPROVAL T. CSIK	9-9-91	1/4 TURN RETAINER	
.XXX ± .010		DO NOT SCALE THIS DRAWING	APPROVAL		
MATERIAL - FINISH		USED ON	SIZE	CODE IDENT. NO.	DRAWING NO.
NEXT ASSY			C	51941	20727
FINAL ASSY			SCALE	2:1	REV. NC
			VT.		SHEET 1 OF 1