

THE INFORMATION AND DESIGN HEREIN WAS ORIGINATED BY AND IS THE PROPERTY OF SKYLOCK INDUSTRIES INCORPORATED. SKYLOCK INDUSTRIES INCORPORATED RESERVES ALL PATENT, PROPRIETARY, DESIGN MANUFACTURING, REPRODUCTION, USE AND SALES RIGHTS THEREOF, AND TO ANY ARTICLE DISCLOSED THEREIN EXCEPT TO THE EXTENT RIGHTS ARE EXPRESSLY GRANTED TO OTHERS. THE FOREGOING DOES NOT APPLY TO VENDOR PROPRIETARY PARTS.

REVISIONS				
ZONE	LTR	DESCRIPTION	DATE	APPROVED
	NC	PRODUCTION RELEASE	10-1-93	T. CSIK

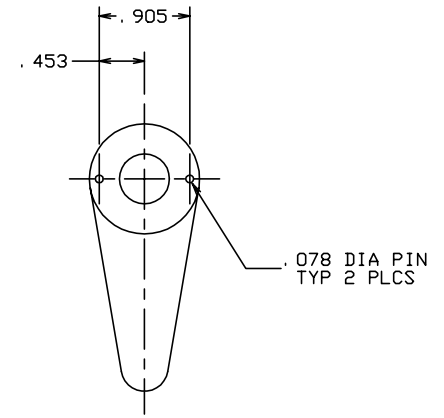
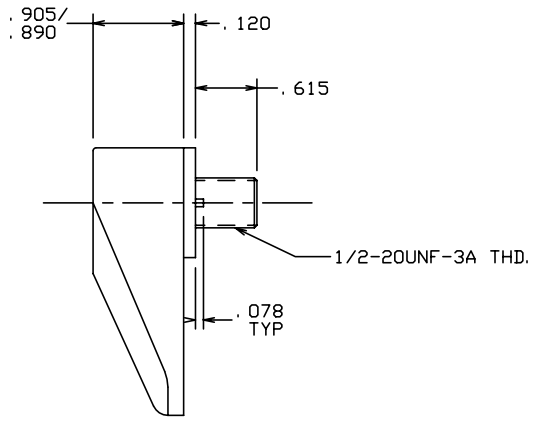
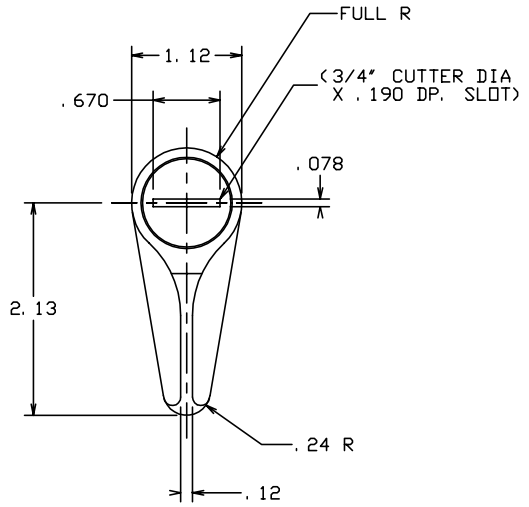

5. SHAFT NEEDS NO TORQUE ADJUSTMENT. TIGHTEN SHAFT AS MUCH AS POSSIBLE WHEN INSTALLING RETAINER.
  4. DECORATIVE FINISH: RETAINER; BRIGHT BUFF AND CANDY APPLE RED ANODIZE, FACE OF BOLT, AND CAM; SATIN BUFF.
  3. FINISH: ALUM.; ANODIZE, CRES PARTS; PASSIVATE.
  2. MAT'L: RETAINER; 2024-T3 ALUM. ALLOY, BOLT; 17-4PH CRES., HEAT TREATED TO COND. H-900 PER MIL-H-6875. ALL OTHER PARTS; 300 SERIES CRES.
  1. REMOVE ALL BURRS AND BREAK SHARP EDGES.
- NOTES: UNLESS OTHERWISE SPECIFIED.

-401		RETAINER ASSY	<180° ROTATION, DETENTED AT EACH 30°>		
PART NO.	DESCRIPTION	MATERIAL SIZE SPECIFICATION			
PARTS LIST					
UNLESS OTHERWISE SPECIFIED		DRAWN BY T. CSIK	10-1-93	SKYLOCK INDUSTRIES INCORPORATED MONROVIA CALIFORNIA U. S. A.	
DIMENSIONS ARE IN INCHES		CHECKED			
TOLERANCES ON		ENGINEER			
DECIMALS ANGLES DRILLED HOLES		PROJECT			
.X ± .1 ± 0° 30' AND 10387		APPROVAL T. CSIK	10-1-93	1/4 TURN RETAINER	
.XX ± .03		APPROVAL			
.XXX ± .010		DO NOT SCALE THIS DRAWING			
MATERIAL - FINISH	USED ON	SIZE	CODE IDENT. NO.	DRAWING NO.	REV.
NEXT ASSY		C	51941	20862	NC
FINAL ASSY	(RGS2925)	SCALE	1: 1	WT.	SHEET 1 OF 1