

THE INFORMATION AND DESIGN HEREIN WAS ORIGINATED BY AND IS THE PROPERTY OF SKYLOCK INDUSTRIES INCORPORATED. SKYLOCK INDUSTRIES INCORPORATED RESERVES ALL PATENT, PROPRIETARY, DESIGN MANUFACTURING, REPRODUCTION, USE AND SALES RIGHTS THERE TO, AND TO ANY ARTICLE DISCLOSED THEREIN EXCEPT TO THE EXTENT RIGHTS ARE EXPRESSLY GRANTED TO OTHERS. THE FOREGOING DOES NOT APPLY TO VENDOR PROPRIETARY PARTS.

REVISIONS				
ZONE	LTR	DESCRIPTION	DATE	APPROVED
	D	ADDED -405	4-30-92	T. CSIK
	E	ADDED -407	1-18-94	T. CSIK
	F	SEE DCR NO. 016	12/9/98	T. CSIK
	G	SEE ECN G	5/25/99	T. CSIK

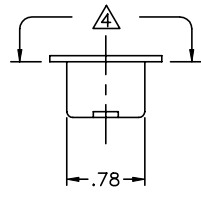

-405 COAT HOOK

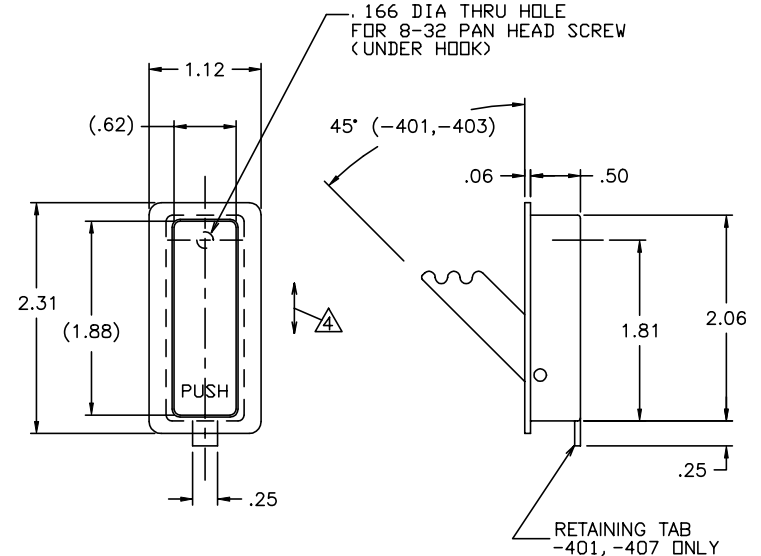
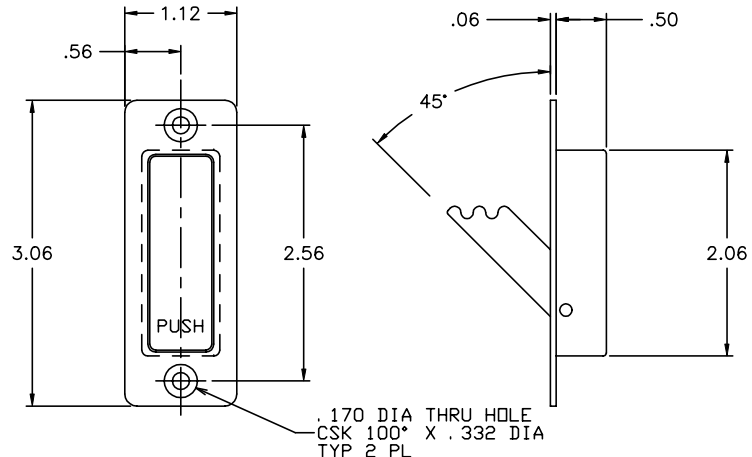
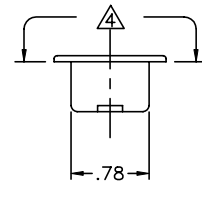

-401 COAT HOOK
-403 COAT HOOK
-407 COAT HOOK

5. PER FAR 45.15. PARTS WILL IDENTIFIED WITH:
1. FAA-PMA.
 2. SKYLOCK IND. INC.
 3. PART NO.
 4. AIRCRAFT ELIGIBILITY.

- △ DECORATIVE FINISH REF.: SATIN BRUSH LENGTHWISE TO PART SURFACE AS INDICATED.
3. FINISH REF.: HOOK & ESCUTCHEON; CLEAR ANODIZE PER MIL-A-8625, TYPE II, CLASS 1 OR EQUIV. CRES. COMPONENTS; PASSIVATE PER AMS-QQ-P-35, TYPE II, OR EQUIV.
 2. MAT'L REF.: HOOK & ESCUTCHEON; 6061-T6/T651 PER ASTM B-221, OR EQUIV. PIN & SPRING; 303 CRES, COND. A, PER AMS-5640N OR EQUIVALENT.
 1. REMOVE ALL BURRS AND BREAK SHARP EDGES.
- NOTES: UNLESS OTHERWISE SPECIFIED.

	-407	COAT HOOK				
	-405	COAT HOOK				
	-403	COAT HOOK				
	-401	COAT HOOK				
PART NO.	DESCRIPTION		MATERIAL	SIZE	APPLICATION	ITEM NO.

PARTS LIST						
UNLESS OTHERWISE SPECIFIED	DRAWN BY	S. CSIK	12-15-92	SKYLOCK INDUSTRIES INCORPORATED MONROVIA CALIFORNIA U. S. A.		
DIMENSIONS ARE IN INCHES	CHECKED	D. VO	12-09/98			
TOLERANCES ON	ENGINEER	T. CSIK	12/09/98			
DECIMALS ANGLES DRILLED HOLES	MFG	P.MATSUOKA	12-15-98			
.X .1 0° 30' AND 10387	Q. C.	J.VIVIRITO	12-28-98	COAT HOOK		
.XX .03	USED ON					
.XXX .010	MATERIAL - FINISH					
DO NOT SCALE THIS DRAWING	MANUFACTURE IN ACCORDANCE WITH SKYLOCK IND. INC., QUALITY CONTROL MANUAL QC.001		SIZE	CODE IDENT. NO.	DRAWING NO.	REV.
			C	51941	20691	G
			SCALE	1:1	WT.	SHEET 1 OF 1