

THE INFORMATION AND DESIGN HEREIN WAS ORIGINATED BY AND IS THE PROPERTY OF SKYLOCK INDUSTRIES INCORPORATED. SKYLOCK INDUSTRIES INCORPORATED RESERVES ALL PATENT, PROPRIETARY, DESIGN MANUFACTURING, REPRODUCTION, USE AND SALES RIGHTS THERE TO, AND TO ANY ARTICLE DISCLOSED THEREIN EXCEPT TO THE EXTENT RIGHTS ARE EXPRESSLY GRANTED TO OTHERS. THE FOREGOING DOES NOT APPLY TO VENDOR PROPRIETARY PARTS.

REVISIONS				
ZONE	LTR	DESCRIPTION	DATE	APPROVED
	NC	PRODUCTION RELEASE	9-27-93	S. CSIK

NOTES: UNLESS OTHERWISE SPECIFIED.

1. MAT'L: ALL COMP'S: 300 SERIES CRES.
2. FINISH: PASSIVATE.
3. DECORATIVE FINISH: SATIN BUFF TOP OF CASE AND HANDLE.
4. NOMINAL LOAD POINT IS .250" FROM TIP OF BOLT. STATIC LOAD IS 800 LBS. MAX. AT NOMINAL LOAD POINT. LATCHES WITH BOLT PROJECTION LONGER THAN .37" REQUIRE REINFORCEMENT IN PANEL/DOOR EDGE TO SUPPORT BOLT LENGTH.

5. SPRING TO RETURN FLAP TO CLOSED POSITION REGARDLESS OF BOLT POSITION.
6. SPRING TO RETURN FLAP OPEN WHEN BOLT IS NOT PROPERLY ENGAGED.
7. LOAD CAPACITY: 250 LBS. MAX.
8. 20847-7 ONLY: FLAP & CASE MAT'L; 17-7 CRES COND. A, HEAT TREAT TO 210 KSI.
9. DECORATIVE FINISH: PLATE BRASS INT. GOLD, MIRROR FINISH TO MATCH BAC92680 (REF TBCF-14.2981). APPLY ONE COAT SHERMAN WILLIAMS CLEAR ENAMEL F63U1.
10. 20847-1-23 ONLY: BOLT MAT'L: HARD DRAWN BRASS.

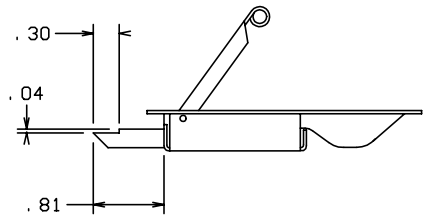
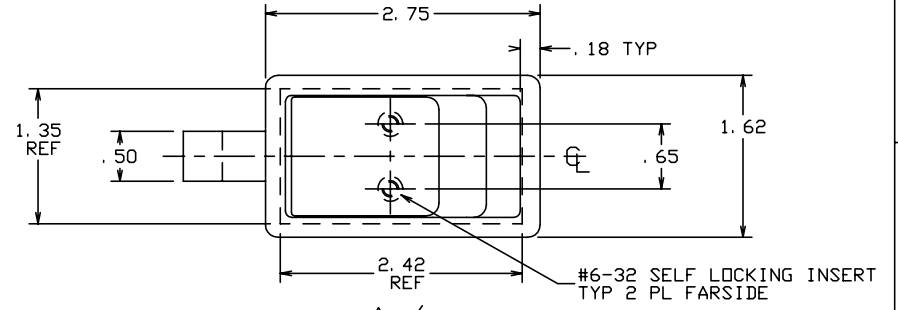

20847-1-37 (9)
(SAME AS -1 EXCEPT AS SHOWN)

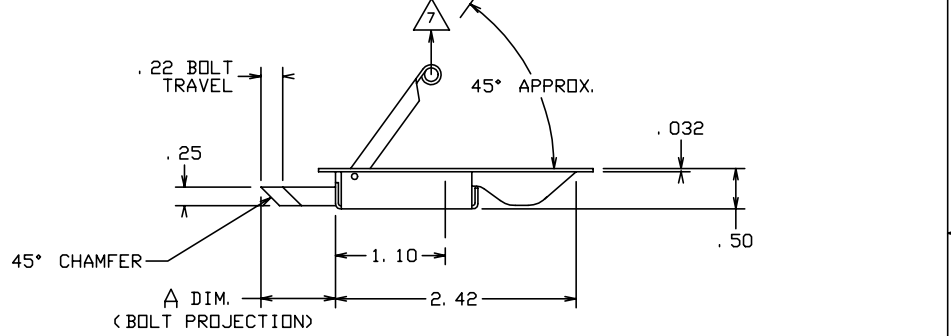

-1, -7 LATCH ASSY (SHOWN)

-39	-41	-43	.52
-31	-33	-35	1.06
-25	-27	-29	.68
-19	-21	-23	1.30
-13	-15	-17	.81
-7	-9	-11	.59
-1	-3	-5	.37
NO FLAP SPRING	CLOSED (5)	OPEN (6)	'A' BOLT PROJ.
SECONDARY DASH NO'S			

PRIMARY DASH NO.	DESCRIPTION	
-10	LATCH ASSY	(ONE HASP, PADLOCK, HINGED)
-9	LATCH ASSY	(ONE HASP, PADLOCK, HINGED)
-7	LATCH ASSY	(NO HASP) (8)
-5	LATCH ASSY	(TWO HASPS, SLOTTED, FIXED)
-3	LATCH ASSY	(ONE HASP, SLOTTED, FIXED)
-1	LATCH ASSY	(NO HASP)

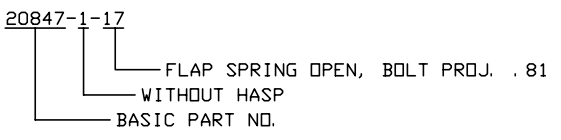

EXAMPLE PART NO.

PARTS LIST		DRAWN BY S. CSIK 9-27-93		SKYLOCK INDUSTRIES INCORPORATED MONROVIA CALIFORNIA U. S. A.									
UNLESS OTHERWISE SPECIFIED		CHECKED		<div style="text-align: center; font-size: 2em; font-weight: bold;">LATCH ASSEMBLY</div>									
DIMENSIONS ARE IN INCHES		ENGINEER											
TOLERANCES ON		PROJECT											
DECIMALS ANGLES DRILLED HOLES		APPROVAL S. CSIK 9-27-93											
.X ± .1 ± 0° 30' AND 10387		APPROVAL		<table border="1" style="width: 100%;"> <tr> <td>SIZE</td> <td>CODE IDENT. NO.</td> <td>DRAWING NO.</td> <td>REV.</td> </tr> <tr> <td>C</td> <td>51941</td> <td>20847</td> <td>NC</td> </tr> </table>		SIZE	CODE IDENT. NO.	DRAWING NO.	REV.	C	51941	20847	NC
SIZE	CODE IDENT. NO.	DRAWING NO.	REV.										
C	51941	20847	NC										
DO NOT SCALE THIS DRAWING		MATERIAL - FINISH		SCALE 1:1									
NEXT ASSY		USED ON		VT.									
FINAL ASSY				SHEET 1 OF 2									

4

3

2

1

REVISIONS				
ZONE	LTR	DESCRIPTION	DATE	APPROVED
		SEE SHT. 1 FOR NOTES		

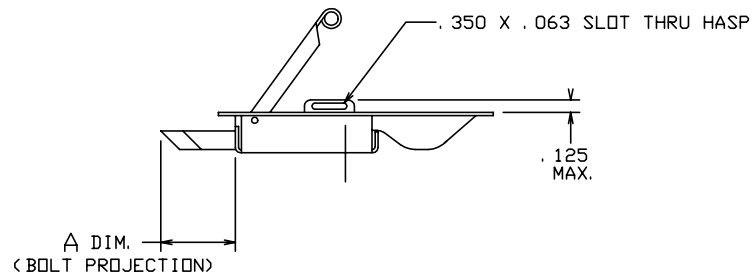
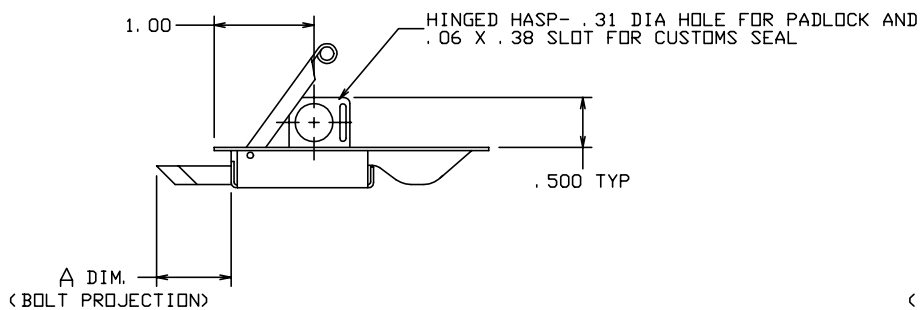
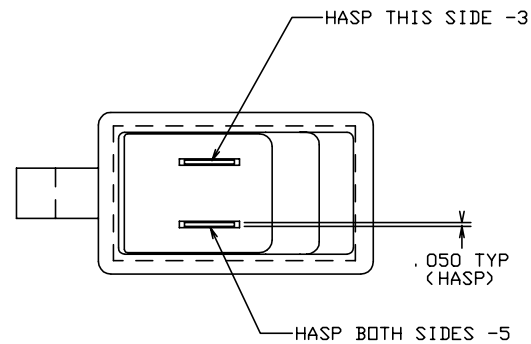
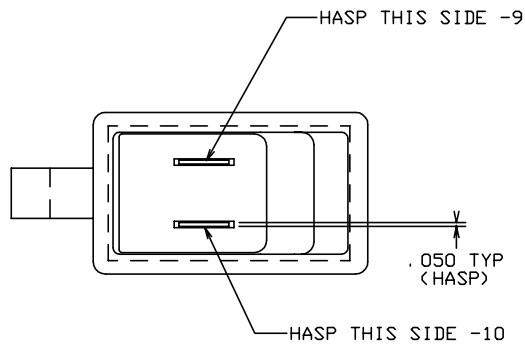

-9, -10 LATCH ASSY (SHOWN)
 (SAME AS -1 EXCEPT AS SHOWN)

-3, -5 LATCH ASSY (SHOWN)
 (SAME AS -1 EXCEPT AS SHOWN)

 SKYLOCK INDUSTRIES INCORPORATED
 MONROVIA CALIFORNIA U. S. A.

LATCH ASSEMBLY

SIZE	CODE IDENT. NO.	DRAWING NO.	REV.
C	51941	20847	NC
SCALE	1: 1	VT.	SHEET 2 OF 2

4

3

2

1