

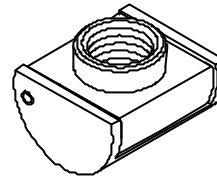

**PAOLO ASTORI s.r.l.**  
 via Gola 84 - MAGGIATE SUP.  
 I 20019 - GATTICO (NO)

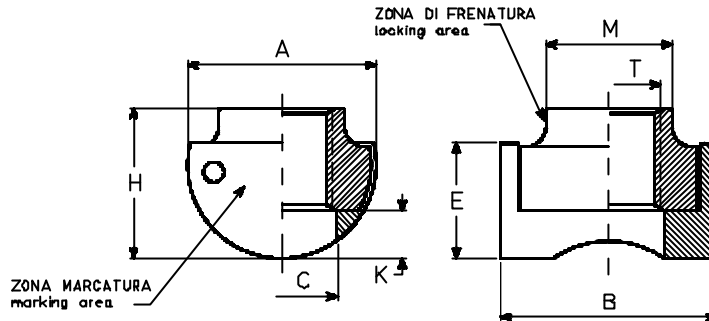

# AFB505



dimensioni in mm.

codice dimensioni	filettatura T	A +0 -0,08	B +0,25 -0	C +0,25 -0	E +0 -0,3.	H max.	K ±0,1	M max.	carico assiale (N)	massa kg x 1000 pezzi
08	M8 x 1,25	14,99	17,48	8,80	9,14	11,89	3,18	10,31	60.800	9,5
10	M10 x 1,5	17,37	19,05	10,80	10,70	13,49	3,96	12,70	90.700	13,6
12	M12 x 1,5	22,15	25,40	12,80	13,72	17,86	5,56	15,88	163.800	37,20
16	M16 x 1,5	26,92	28,60	16,80	16,60	21,44	7,14	19,05	253.100	81,7
18	M18 x 1,5	32,46	38,10	18,80	19,05	26,98	8,74	22,23	377.600	104,3
20	M20 x 1,5	36,40	38,89	20,80	21,59	29,34	10,16	25,40	459.900	150,0

codice materiali	materiale	finitura- dado                      barilotto		classe resistenza	classe temperatura
<b>DADO E BARILOTTO AFB505</b>	SAE4340 per MIL-S-5000 Hrc 38 - 44	cadmiatura + MoS <sub>2</sub>	cadmiatura	1550 MPa	235°C
<b>SPINA AFB505</b>	Cres AISI 302	Passivazione per QQ-P-35			

FILETTO: profilo ISO 68; diam. interno secondo profilo MJ  
 ISO 5855. Tolleranza 4H-5H.

FLOTTAGGIO: trasversale mm. 0,4 minimo dal centro; longitudinale e verticale mm. 0,4 max.

MARCATURA: AFB505 - codice dimensioni.

METALLOSCOPIO: controllo al 100% sul dado e sul barilotto per MIL-STD-1949A

CADMIATURA : secondo QQ-P-416 tipo II classe 2.

LUBRIFICAZIONE : Lubrificante MoS<sub>2</sub> in accordo a MIL-L-46010

NORMA di costruzione e controllo: LN65016.

Riferimenti UA 22006 EF346	Reference spec.	<b>DADO BARILOTTO AUTOFREANANTE, FLOTTANTE BARREL NUT, SELF-LOCKING FLOATING</b>	<b>AFB505</b>
----------------------------------	-----------------	--	---------------