

4

3

2

1

THE INFORMATION AND DESIGN HEREIN WAS ORIGINATED BY AND IS THE PROPERTY OF SKYLOCK INDUSTRIES INCORPORATED. SKYLOCK INDUSTRIES INCORPORATED RESERVES ALL PATENT, PROPRIETARY, DESIGN MANUFACTURING, REPRODUCTION, USE AND SALES RIGHTS THERE TO, AND TO ANY ARTICLE DISCLOSED THEREIN EXCEPT TO THE EXTENT RIGHTS ARE EXPRESSLY GRANTED TO OTHERS. THE FOREGOING DOES NOT APPLY TO VENDOR PROPRIETARY PARTS.

REVISIONS				
ZONE	LTR	DESCRIPTION	DATE	APPROVED
	NC	PRODUCTION RELEASE	10-27-97	T. CSIK
	A	SEE ECN A	4/14/99	T. CSIK

- NOTES: UNLESS OTHERWISE SPECIFIED.
- REMOVE ALL BURRS AND BREAK SHARP CORNERS.
 - MAT'L REF.: TURN; 6061-T6/T651 PER ASTM B-221, OR EQUIV. CAM; 303 CRES, COND. A, PER AMS-5640N OR EQUIV.
 - FINISH REF.: TURN-SATIN BRUSH DIRECTION NOTED AND ANODIZE PER MIL-A-8625, TYPE II, CLASS 2, DYED CANDY APPLE RED.
 - PER FAR 45.15. PARTS WILL BE IDENTIFIED WITH:
 1. FAA-PMA.
 2. SKYLOCK IND. INC.
 3. PART NO.
 4. AIRCRAFT ELIGIBILITY.

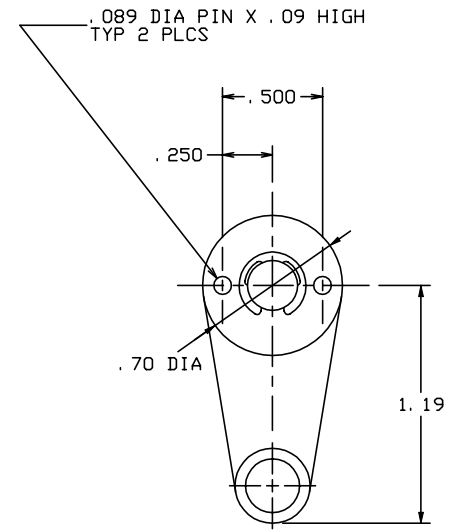
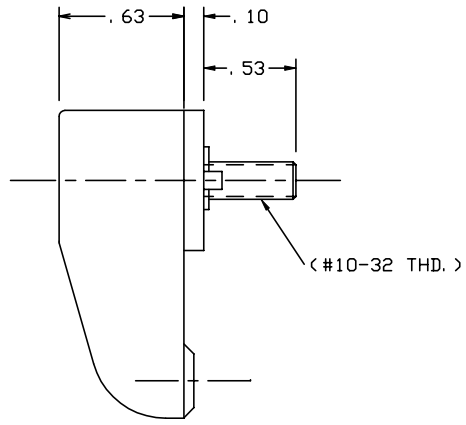
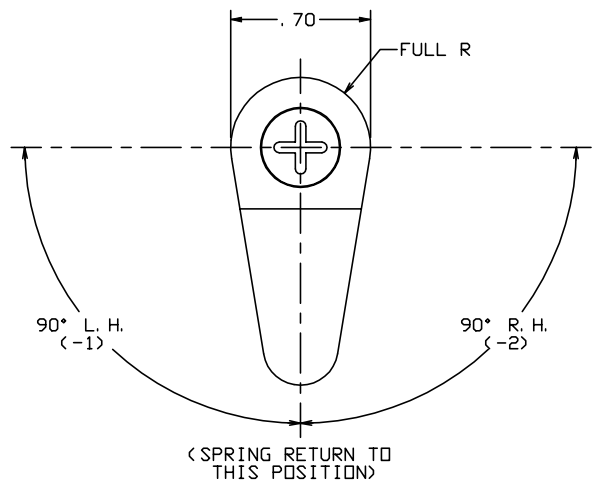

-1, -2 1/4 TURN (SHOWN)

	-2	1/4 TURN	(SHOWN-R. H.)	120950-202
	-1	1/4 TURN	(SHOWN-L. H.)	120950-201
PART NO.	DESCRIPTION		MAKE FROM	

PARTS LIST				
UNLESS OTHERWISE SPECIFIED	DRAWN BY	T. CSIK	10-27-97	SKYLOCK INDUSTRIES INCORPORATED MONROVIA CALIFORNIA U. S. A.
DIMENSIONS ARE IN INCHES	CHECKED	T. CSIK	4/13/99	
TOLERANCES ON	ENGINEER	T. CSIK	4/13/99	
DECIMALS ANGLES DRILLED HOLES	MFG	P. MATSUOKA	4/30/99	
	QC	J. VIVIRITO	5/7/99	
DO NOT SCALE THIS DRAWING				
MATERIAL - FINISH	USED ON	SIZE	CODE IDENT. NO.	DRAWING NO.
NEXT ASSY		C	51941	20950
MANUFACTURE IN ACCORDANCE WITH SKYLOCK IND. INC., QUALITY CONTROL MANUAL QC.001		SCALE	2: 1	VT.
			SHEET	1 OF 1

1/4 TURN - SPRING RETURN

4

3

2

1