

PAOLO ASTORI

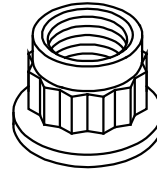

PAOLO ASTORI s.r.l.
via Mirabella 9-MAGGIATE SUP.
I 28013-GATTICO (NO)



DP30

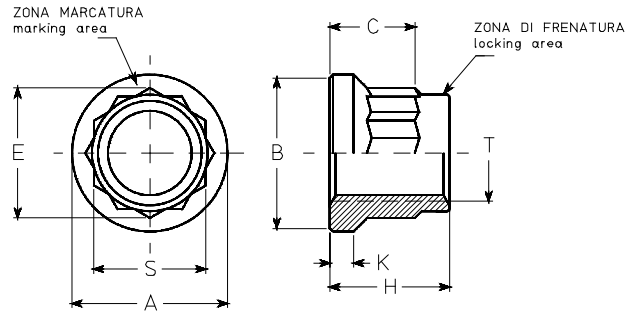

dimensions in mm

TABLE 1

dimension code	thread	T	A h12	B min.	C max.	E min.	H h14	K min	S h12	Mass (kgx1000)
05	MJ5x0,8	4H-6H	9,1	8,3	4,6	7,8	7	1,2	7,0	1,63
06	MJ6x1	4H-5H	10,6	9,8	5,2	8,9	8,1	1,2	8,0	2,33
07	MJ7x1	4H-5H	12,1	11,3	5,7	10,0	9,1	1,2	9,0	3,19
08	MJ8x1	4H-5H	13,6	12,8	6,9	11,2	10,4	1,2	10,0	4,34
10	MJ10x1,25	4H-5H	16,8	15,8	8,8	13,4	13,0	1,2	12,0	7,69
12	MJ12x1,25	4H-5H	19,9	18,8	10,1	15,6	15,0	1,4	14,0	14,58
14	MJ14x1,5	4H-5H	23,0	21,9	12,6	18,9	17,5	1,7	17,0	19,79
16	MJ16x1,5	4H-5H	26,0	24,9	14,0	21,1	19	2,5	19,0	
18	MJ18x1,5	4H-5H	29,1	28	16,0	24,5	22	3,0	22,0	
20	MJ20x1,5	4H-5H	32,3	31,2	18,0	26,7	24,5	3,0	24,0	

TABLE 2

material code	material	finish	hardness HRC	strenght class	temperatur e class
DP30X	EN2399 A286	passivation	28-36	1100 MPa	650°C
DP30L		passivation+MoS ₂			315°C
DP30A		silver plating			650°C

MATERIAL: A286 iaw EN2399 or equivalent
 THREAD: ISO5855 Part 1 and Part 2
 FINISH: MoS₂ EN2491. Silver plating EN2786
 PROCUREMENT SPEC. ISO5858
 MARKING: Manufacturer identification symbol and letters MJ
 ASTORI CALL UP: Material code- dimension code. Example: DP30L-08 (passivator + MoS₂ MJ 8x1)

References
EN2906
EN3720
EN2907
(up to diam. 14)

**NUT, 12 POINTS, SELF-LOCKING,
CRES,1100 MPa**

DP30