

THE INFORMATION AND DESIGN HEREIN WAS ORIGINATED BY AND IS THE PROPERTY OF SKYLOCK INDUSTRIES INCORPORATED. SKYLOCK INDUSTRIES INCORPORATED RESERVES ALL PATENT, PROPRIETARY, DESIGN MANUFACTURING, REPRODUCTION, USE AND SALES RIGHTS THERE TO, AND TO ANY ARTICLE DISCLOSED THEREIN EXCEPT TO THE EXTENT RIGHTS ARE EXPRESSLY GRANTED TO OTHERS. THE FOREGOING DOES NOT APPLY TO VENDOR PROPRIETARY PARTS.

REVISIONS				
ZONE	LTR	DESCRIPTION	DATE	APPROVED
	NC	PRODUCTION RELEASE	6-25-92	T. CSIK

- NOTES: UNLESS OTHERWISE SPECIFIED.
1. REMOVE ALL BURRS AND BREAK SHARP EDGES.
 2. MAT'L: STUD AND CAM; ST. STL., HOUSING; ALUM. ALLOY.
 3. FINISH: ST. STL.; PASSIVATE, ALUM.; CLEAR ANODIZE.

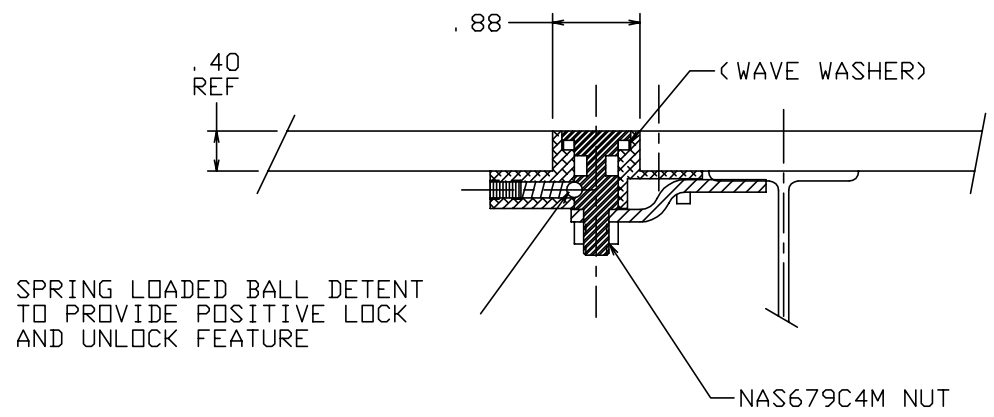

SPRING LOADED BALL DETENT TO PROVIDE POSITIVE LOCK AND UNLOCK FEATURE

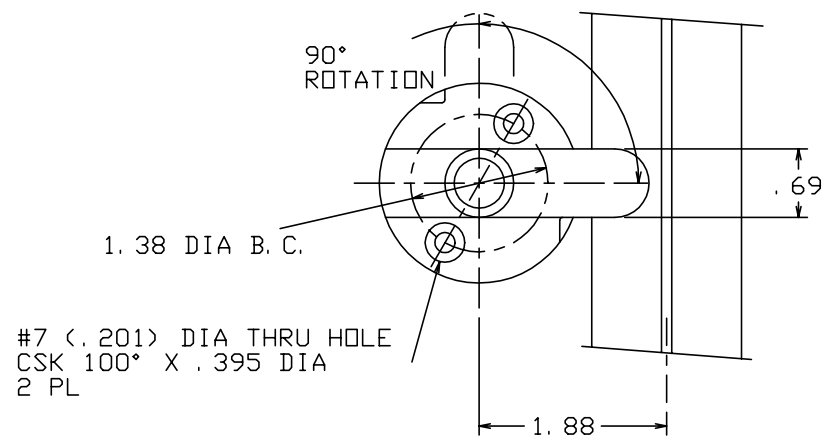

		-401	LATCH ASSY				
QTY REQD	PART NO.	DESCRIPTION		MATERIAL SIZE SPECIFICATION		ITEM NO.	
PARTS LIST							
UNLESS OTHERWISE SPECIFIED			DRAWN BY	T. CSIK	6-19-92	 SKYLOCK INDUSTRIES INCORPORATED MONROVIA CALIFORNIA U. S. A.	
DIMENSIONS ARE IN INCHES			CHECKED				
TOLERANCES ON			ENGINEER				
DECIMALS ANGLES DRILLED HOLES			PROJECT				
.X ± .1 ± 0° 30' AND 10387			APPROVAL	T. CSIK	6-19-92		
.XX ± .03							
.XXX ± .010							
DO NOT SCALE THIS DRAWING			APPROVAL			LATCH ASSY CARGO FLOOR PANEL	
MATERIAL - FINISH		USED ON	SIZE	CODE IDENT. NO.	DRAWING NO.		REV.
NEXT ASSY			C	51941	20776		NC
FINAL ASSY			SCALE	1: 1	VT.		SHEET 1 OF 1