

4

3

2

1

THE INFORMATION AND DESIGN HEREIN WAS ORIGINATED BY AND IS THE PROPERTY OF SKYLOCK INDUSTRIES INCORPORATED. SKYLOCK INDUSTRIES INCORPORATED RESERVES ALL PATENT, PROPRIETARY, DESIGN MANUFACTURING, REPRODUCTION, USE AND SALES RIGHTS THERE TO, AND TO ANY ARTICLE DISCLOSED THEREIN EXCEPT TO THE EXTENT RIGHTS ARE EXPRESSLY GRANTED TO OTHERS. THE FOREGOING DOES NOT APPLY TO VENDOR PROPRIETARY PARTS.

REVISIONS

ZONE	LTR	DESCRIPTION	DATE	APPROVED
	NC	PRODUCTION RELEASE	9-25-91	T. CSIK
	A	ADDED -403, -405	2-27-96	T. CSIK

NOTES: UNLESS OTHERWISE SPECIFIED.

- REMOVE ALL BURRS AND BREAK SHARP EDGES.
- MAT'L: RETAINER; ALUM. ALLOY, ALL OTHER PARTS; 300 SERIES CRES. (-401, -403), RETAINER AND ALL OTHER PARTS; 300 SERIES CRES (-405).
- FINISH: ALUM.; ANODIZE, CRES PARTS; PASSIVATE.
- DECORATIVE FINISH: RETAINER; BRIGHT BUFF AND CANDY APPLE RED ANODIZE PER MIL-A-8625 (-401), SATIN BRUSH AND CLEAR ANODIZE PER MIL-A-8625 (-403), SATIN BRUSH, AND PASSIVATE PER QQ-P-35 (-405).
- STATIC LOAD: 800 LBS. MAX.

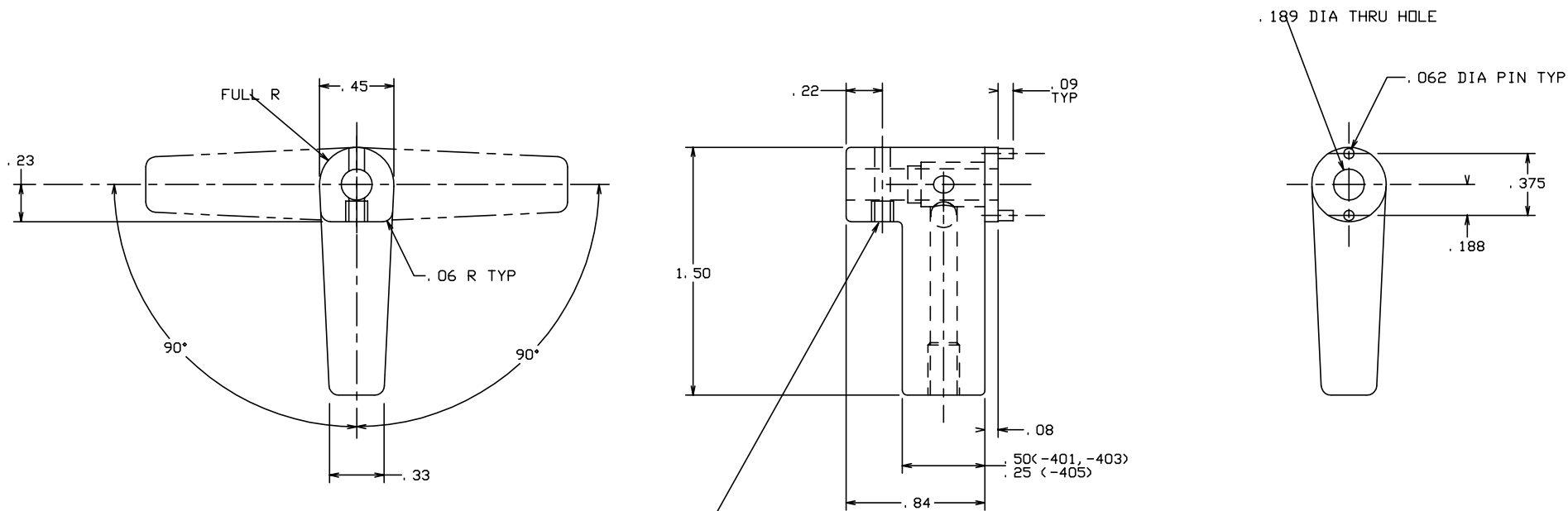

THREADED PIN WITH HEX SOCKET HEAD
DRILL .093 DIA HOLE THRU TUBE AT INSTL

	-405	RETAINER ASSY	(SATIN CRES)		
	-403	RETAINER ASSY	(CLEAR)		
	-401	RETAINER ASSY	(CANDY APPLE RED)		
PART NO.	DESCRIPTION	MATERIAL	SIZE	SPECIFICATION	ITEM NO.

PARTS LIST

UNLESS OTHERWISE SPECIFIED	DRAWN BY T. CSIK	9-25-91	 SKYLOCK INDUSTRIES INCORPORATED MONROVIA CALIFORNIA U. S. A.	1/4 TURN RETAINER	
DIMENSIONS ARE IN INCHES	CHECKED				
TOLERANCES ON	ENGINEER				
DECIMALS ANGLES DRILLED HOLES	PROJECT				
.X ± .1 ± 0° 30' AND 10387	APPROVAL T. CSIK	9-25-91			
.XX ± .03	APPROVAL				
.XXX ± .010					
DO NOT SCALE THIS DRAWING					
MATERIAL - FINISH	USED ON	SIZE	CODE IDENT. NO.	DRAWING NO.	REV.
NEXT ASSY		C	51941	20733	A
FINAL ASSY		SCALE	2: 1	WT.	SHEET 1 OF 1

4

3

2

1