

REVISIONS			
SYMBOL	DESCRIPTION	DATE	BY
	EFFECTIVE ON	DISP EXIST PARTS	APPROVAL
A	REVISED/REDRAWN	5-24-79	JEE

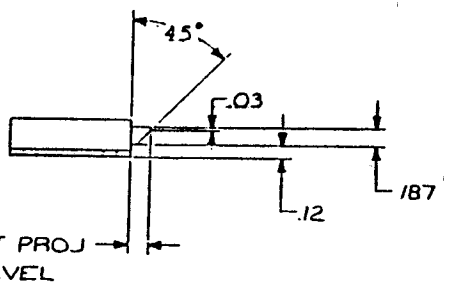
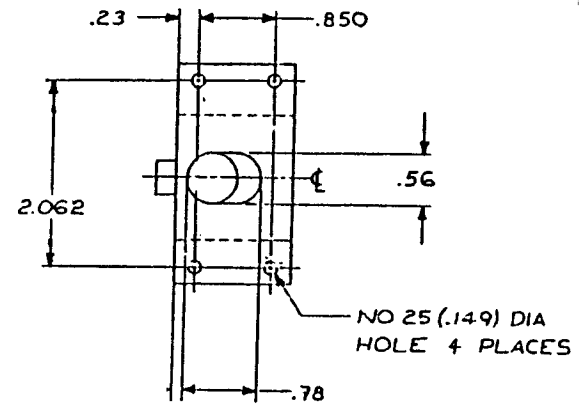
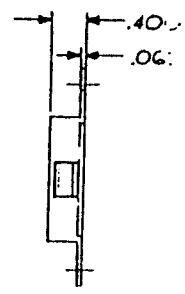
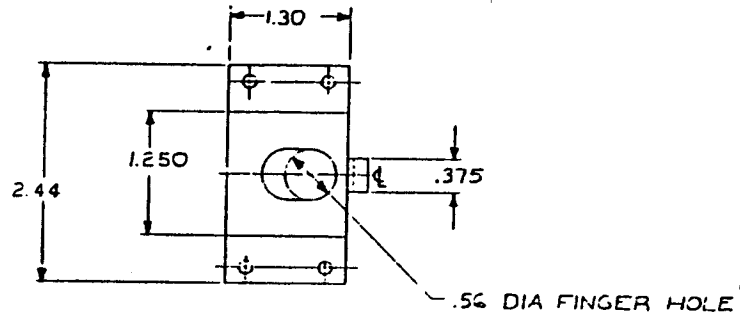

- 3 BOLT IS SPRING LOADED TO EXTENDED POSITION
- 2 FINISH : ALUM-CLEAR ANODIZE, CRES-PASSIVATE
- 1 MAT'L : HOUSING-ALUM, SPRING-CRES BOLT : NYLON 6/6

NOTES : UNLESS OTHERWISE SPECIFIED

-1		LATCH ASSY	
PART NUMBER		DESCRIPTION	
MATERIAL OR NOTE		LIST OF MATERIAL	
UNLESS OTHERWISE NOTED DIMENSIONS ARE IN INCHES. TOLERANCES ON DECIMALS XX ± .03 XXX ± .010 ANGLES ± DRILLED HOLES PER ANSI B3.1		CONTRACT NO.	
SURFACE ROUGHNESS		DRAFTSMAN JEE	
HEAT TREAT		CHECKER <i>M. J. J.</i>	
FINISH		ENGINEER JEE	
INSPECT		PROD. APPD <i>[Signature]</i>	
REF. NO.		APPROVAL <i>[Signature]</i>	
		SKYLOCK INDUSTRIES, INC. SO. EL MONTE, CALIFORNIA	
		FINGER LATCH	
SIZE	CODE IDENT NO.	20310	
C	51941		
SCALE 1/1	WT CALC	WT ACT	SHEET 1 OF 1

20310